

**Warning:** filectime(): stat failed for /var/www/vhost/www.omal.it/htdocs/https://www.omal.it./FilesProdotti/Certificato-PED-DNV.pdf in /var/www/vhost/www.omal.it/htdocs/prodotto-printable.php on line 65

**Warning:** filectime(): stat failed for /var/www/vhost/www.omal.it/htdocs/https://www.omal.it./FilesProdotti/80489-02-VIPATEX-IT-EN-0522.pdf in /var/www/vhost/www.omal.it/htdocs/prodotto-printable.php on line 65

**Warning:** filectime(): stat failed for /var/www/vhost/www.omal.it/htdocs/https://www.omal.it./FilesProdotti/RICEVUTADEPOSITOF.T.ATEXN.VAP-19.pdf in /var/www/vhost/www.omal.it/htdocs/prodotto-printable.php on line 65

**Warning:** filectime(): stat failed for /var/www/vhost/www.omal.it/htdocs/https://www.omal.it./FilesProdotti/81607-VIPnuovomodello-IT-EN-DE-ES.pdf in /var/www/vhost/www.omal.it/htdocs/prodotto-printable.php on line 65

**Warning:** filectime(): stat failed for /var/www/vhost/www.omal.it/htdocs/https://www.omal.it./FilesProdotti/UIT00A70AOX-VIPoxygenuse-IT-EN.pdf in /var/www/vhost/www.omal.it/htdocs/prodotto-printable.php on line 65

## VIP (new model) - Válvulas de Interceptación Neumática



Macro Válvulas neumáticas

Categoría VIP (new model) - Válvulas de Interceptación Neumática

ventajas

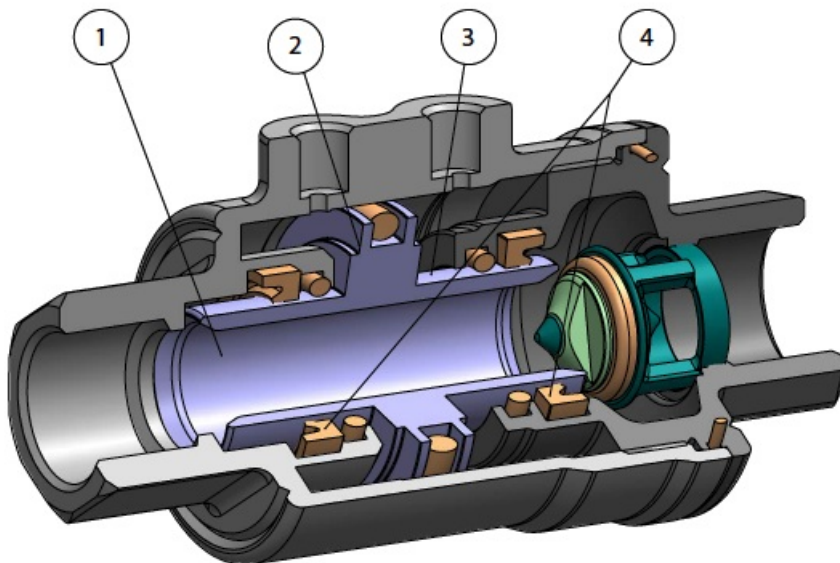

**1. Internal diameter equal to the diameter of the pipe**

Optimised geometry to maximise flow rate

**2. Pneumatic actuator integrated in the valve**

Space saving (-60%) and reduced costs compared to an automated valve

**3. Piston with chemical nickel plating (20-25 micron)**

Lower wear of the seals due to the increase of the surface hardness (400-550 HV)

**4. Lip seals**

Less wear of the seal comparing with an o-ring

**Several seal materials available**

Maximum compatibility with different types of fluids depending by the seals used

**No external moving parts**

Maximum safety

Easy mounting

**Long life time granted**

Lifetime 10 times longer than a ball valve with with reduced maintenance costs

**100% in-house manufacturing process technology**

Maximum control and accuracy in all the stages of the manufacturing process

**Less Air consumption**

80% less air consumption compared to an actuated valve with SR pneumatic actuator therefore less load on the compressor or the possibility of using a smaller compressor's size.

**ATEX Certificate**

Installation is allowed in a potential explosive environment

**PED Certificate**

Full compliance with European Safety Standards for Pressure Equipment

## características

### GENERAL FEATURES:

- Both Double Acting and Spring Return VIP valves (either Normally Open or Normally Closed) are available in sizes ranging from 3/8" to 2".
- Unidirectional flow.
- GAS threaded ends as per EN 10226-1 Rp (ISO 7/1) - DIN 2999 (NPT threads on request) with control fluid connections as per NAMUR interface (optional).
- Improved fluid dynamics allow minimum pressure losses. See Flow Pressure Diagram.
- VIP valves can be used in any mounting position (horizontal, vertical or oblique).
- They can be provided with seals in NBR, FKM or EPDM:
  - **NBR**: suitable for air, gaseous fluids, oils, water etc.
  - **FKM**: perfectly suitable for most fluid. Unsuitable for steam.
  - **EPDM**: perfectly suitable for hot water. Unsuitable for mineral products (oils, grease, etc.).
- Possibility to check open / close valve position thanks to inductive limit switches (magnetic contact) available on request. Internal magnet needs to be requested at VIP order phase.
- Leakage rate class VI according to IEC 60534-4 (ANSI-FCI 70-2 class VI).
- **According to 2014/68/EU "PED"**.
- **2014/34/EU ATEX configuration to request at time of order.**

### CONTROL MEDIA:

- Filtered compressed air, not necessarily lubricated. At temperatures from -20°C to 0°C, use dry air.
- In case of lubricated air, seal compatible oil must be used.
- Air supply: 3 bar min.- 8.5 bar max. in Double Acting execution. 4,2 bar min.- 8.5 bar max. in Spring Return execution.

### OPERATING MEDIA:

- Pressure: 10 bar max, see diagram.
- Temperature:
  - NBR (also version with magnet): from -20°C (-4°F) a +80°C (176°F)
  - EPDM and FKM without magnet: from -20°C (-4°F) a +150°C (302°F)
  - EPDM and FKM with magnet: from -20°C (-4°F) a +90°C (194°F)
- Vacuum tightness: 97% vacuum (about 30 mbar absolut, -980 mbarg). Leakage rate <10<sup>-6</sup> mbar-l/s (Value less than 2g of air at room temperature per year).

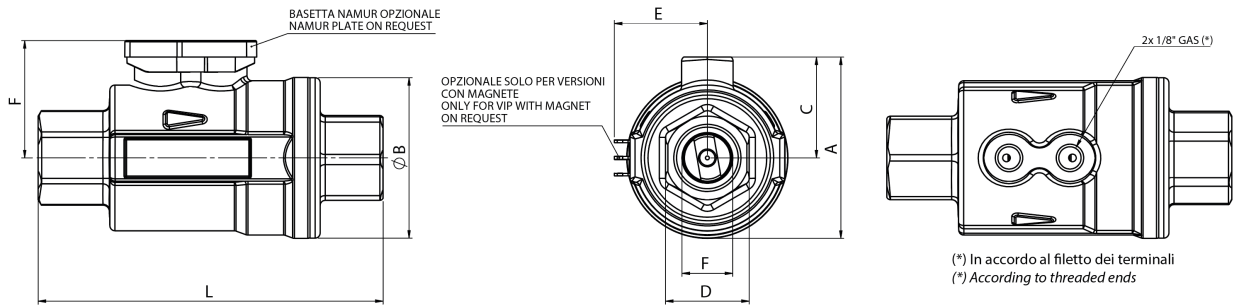
**dimensiones**

**DIMENSIONS**

DN nominal diameter	mm	10	15	20	25	32	40	50
Size F	GAS/NPT	3/8"	1/2"	3/4"	1"	1 1/4"	1 1/2"	2"
Bore	mm [in]	10 [0.39]	15 [0.59]	20 [0.79]	25 [0.98]	32 [1.26]	40 [1.57]	50 [1.97]
A	mm [in]	53,5 [2.11]	58,95 [2.32]	70,75 [2.79]	76 [2.99]	91 [3.58]	102 [4.02]	114,3 [4.50]
B	mm [in]	46 [1.81]	51,7 [2.04]	63,5 [2.5]	69 [2.72]	86 [3.39]	96 [3.78]	109 [4.29]
C	mm [in]	30,5 [1.2]	33,1 [1.3]	39 [1.54]	41,5 [1.63]	48 [1.89]	54 [2.13]	59,8 [2.35]
Ch.D	mm [in]	22 [0.87]	27 [1.06]	33 [1.3]	41 [1.61]	50 [1.97]	60 [2.36]	70 [2.76]
E	mm [in]	28,2 [1.11]	31,1 [1.22]	37,5 [1.48]	38,5 [1.52]	45,7 [1.8]	51,1 [2.01]	57,1 [2.25]
F	mm [in]	37 [1.46]	39,6 [1.56]	45,5 [1.79]	48 [1.89]	54,5 [2.15]	60,5 [2.38]	66,3 [2.61]
L (GAS)	mm [in]	98 [3.86]	112 [4.41]	135 [5.31]	143 [5.63]	165 [6.5]	180 [7.09]	205 [8.07]
L (NPT)	mm [in]	92,5 [3.64]	106 [4.17]	126 [4.96]	136 [5.35]	154 [6.06]	171 [6.73]	187 [7.36]
Double acting air	dm <sup>3</sup> /ciclo [in <sup>3</sup> /cycle]	0,024 [1.46]	0,042 [2.56]	0,074 [4.52]	0,082 [5]	0,15 [9.15]	0,218 [13.3]	0,253 [15.8]
Spring return air	dm <sup>3</sup> /ciclo [in <sup>3</sup> /cycle]	0,011 [0.67]	0,021 [1.28]	0,034 [2.07]	0,037 [2.26]	0,069 [4.21]	0,1 [6.1]	0,127 [7.9]
Weight double acting "DA"	kg [lb]	0,6 [1.3]	0,8 [1.8]	1,3 [2.9]	1,7 [3.6]	2,8 [6.2]	3,7 [8.2]	5,1 [11.2]
Weight spring return "SR"	kg [lb]	0,6 [1.3]	0,85 [1.9]	1,4 [3]	1,8 [4]	3 [6.5]	3,9 [8.6]	5,4 [11.9]
Approx. switching time	ms	40	55	60	70	80	120	160

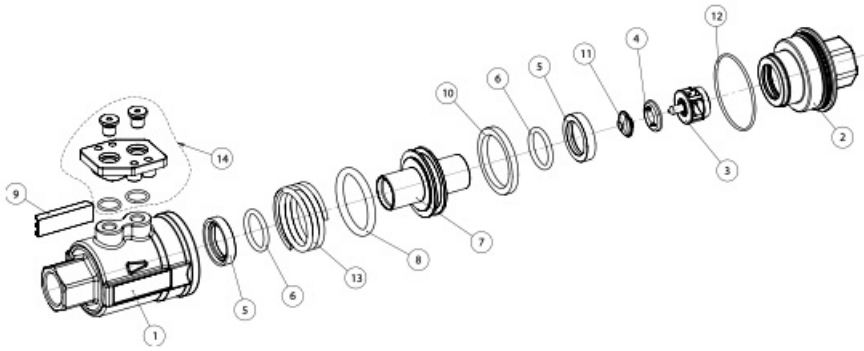
## materiales



MATERIALS				
Pos.	Description	Q.ty	Material	Treatment
1	body	1	brass CW617N	nickel plated
2	sleeve	1	brass CW617N	nickel plated
3	seat	1	brass CW617N	nickel plated
4*	seat-seal	1	NBR/EPDM/FKM	-
5*	lip seal	2	NBR/EPDM/FKM	-
6*	stem O-ring	2	NBR/EPDM/FKM	-
7	piston	1	brass CW617N	nickel plated
8*	piston o-ring	1	NBR/EPDM/FKM	-
9**	limit switch bracket	1	PA6+20% Glass	-
10**	magnetic ring	1	plastroferrite	-
11	seat nut	1	brass CW614N	nickel plated
12*	sleeve O-ring	1	NBR/EPDM/FKM	-
13	spring	1	302 S.S.	-
14**	Kit Namur plate	1	PA66+30% Glass, brass inserts	

\* Components of spare part kit

\*\* Optional parts

## diagramas y pares de aceleración

3.21 · PNEUMATIC VALVES > VIP > VIP ACCESSORIES

OMAL S.p.A.

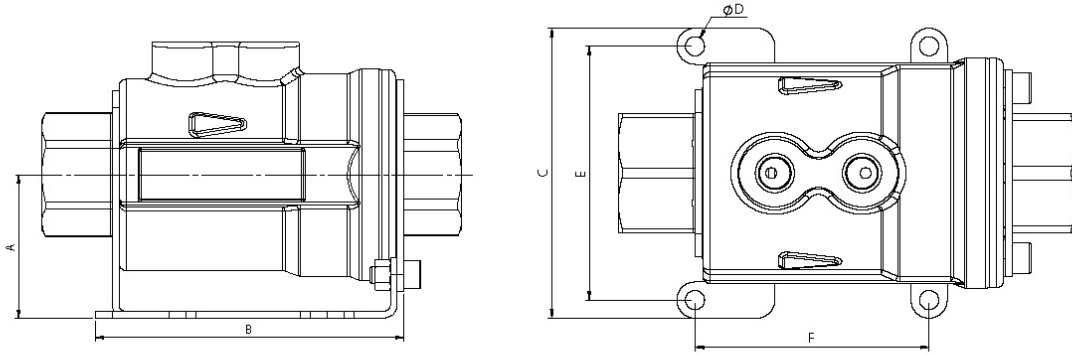

STAFFA DI FISSAGGIO			FIXING BRACKET						
	GAS/NPT	CODICE/CODE	A	B	C	ØD	E	F	
DN10	3/8"	K00V0003	36	71.5	64	5.4	54	61.5	
DN15	1/2"	K00V0004	39	80	69	5.4	59	68	
DN20	3/4"	K00V0005	43	92.5	80	5.4	70	64.5	
DN25	1"	K00V0006	46	99	86	5.4	76	71	
DN32	1 1/4"	K00V0007	58	116.5	110	6.4	96	81.5	
DN40	1 1/2"	K00V0008	63	122	120	6.4	106	84.5	
DN50	2"	K00V0009	64	139	132	6.4	118	100	

DIAGRAMMA PORTATA - PERDITA DI CARICO E COEFFICIENTE NOMINALE  
 FLOW PRESSURE DROP DIAGRAM AND Kv NOMINAL COEFFICIENT



DIAGRAMMA PRESSIONE TEMPERATURA  
 PRESSURE TEMPERATURE DIAGRAM



## SCHEMI DI FUNZIONAMENTO WORKING PLAN

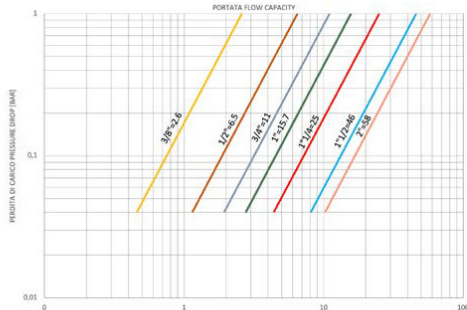
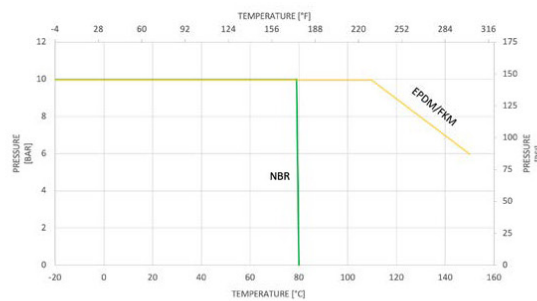
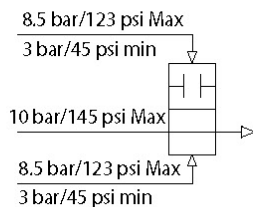

Schema di funzionamento nella configurazione doppio effetto  
*Double acting VIP Working plan*

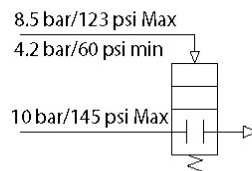

Schema di funzionamento nella configurazione semplice effetto normalmente chiuso  
*Spring return Normally closed VIP Working plan*

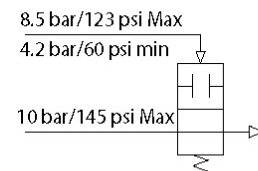

Schema di funzionamento nella configurazione semplice effetto normalmente aperto  
*Spring return Normally open VIP Working plan*

## especificaciones

### Working principle

A VIP valve (patented by OMAL exclusively) is a proper automatic valve embodying both interception device (between pipe C-D) and control device (A-B).

It works thanks to the internal movement of a piston supplied with air. At the end of its stroke (a VIP valve is an ON/OFF valve), the piston presses on the seat seal or moves away from it letting the intercepted fluid flow or stopping it from flowing. As the seat is perfectly tight and the intercepted fluid pressures discharge on it, the pressure necessary to move the piston is completely independent of the fluid pressure. As a result OMAL has been able to design a light space saving and lasting valve. Its full bore and its improved internal dynamics allow minimum pressure losses, too.

### Closed valve

Supplying the hole "A" with air (the hole "B" must be discharging) at the end of its stroke the piston presses on the seat seal: the valve is closed.

As in Spring Return N.C. executions the spring is in "A", if there is no control, the piston will touch the seat seal: therefore, the preferable position is the closed one.

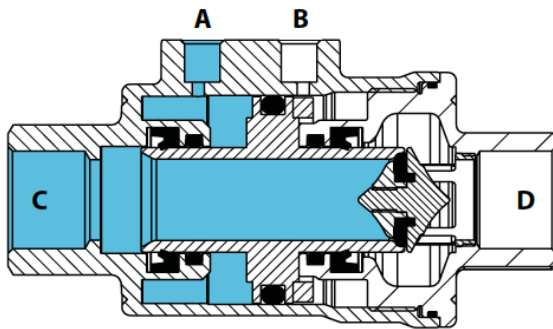

### Transitional phase

During the transitional phase (the picture shows the opening transition in a Double Acting execution), one of the two holes is supplied. The piston moves axially changing the previous closed or open state. In Spring Return N.C. executions, the closing is caused by the spring (if there is no control). In Spring Return N.O. executions, the opening is caused by the spring (if there is no control). Both opening and closing transitional phases last less than a second.

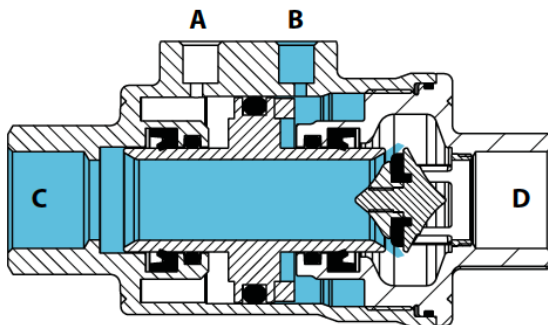

#### Opened valve

Supplying the hole "B" with air (the hole "A" must be discharging) at the end of its stroke the piston is at maximum distance from the seat seal: the valve is open.

As in Spring Return N.O. executions the spring is in "B", if there is no control, the piston will be away from the seat seal: therefore, the preferable position is the open one.

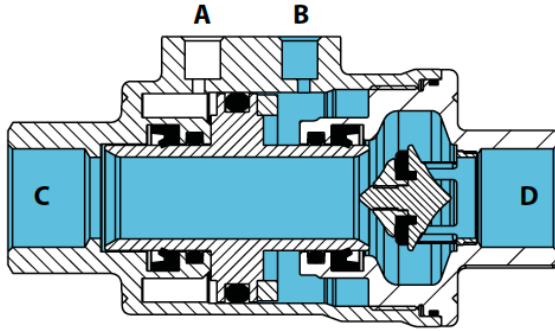



## accesorios

NAMUR SOLENOID VALVE					
Solenoid valve	ER8188A2	ER8188A4	ER8188A5	ER8188C2	ER8188C4
Voltage	24V AC	115V AC	230V AC	24V DC	110V DC

MICRO SOLENOID VALVE					
Solenoid valve	EP415024	EP415110	EP415220	EP412012	EP412024
Voltage	24V AC	115V AC	230V AC	12V DC	24V DC

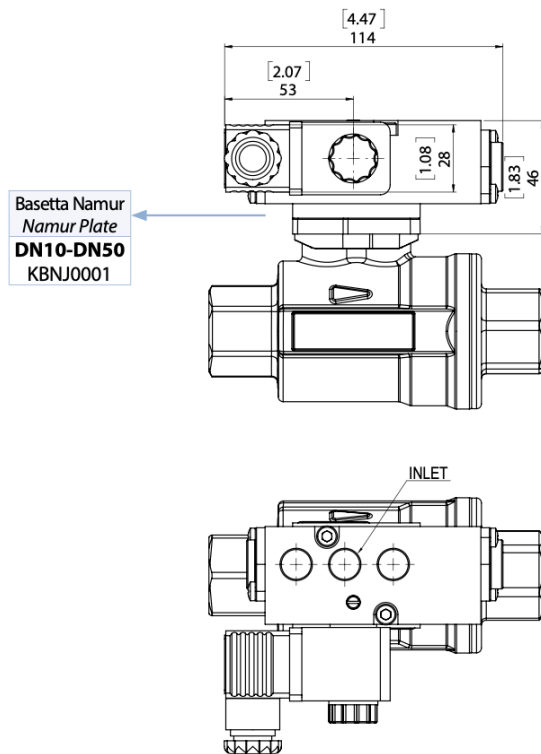

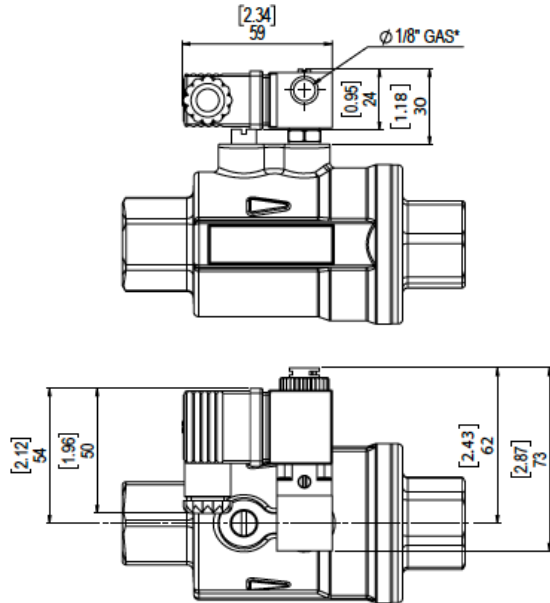

#### Solenoid valve 5/2 as per NAMUR

- This solenoid valve is designed for the selection of the functions 5/2 and 3/2, which is realized by using the appropriate plate.
- Full-working input power - D.C.: 2,5 W.
- Full-working input power - A.C.: 2 W.
- Supply voltage tolerances: +/- 10%.
- Coil insulation: F-class.
- Protection with connector: IP65.
- Electric connection: PG 9.
- Pneumatic connections: inlet 1/4"; outlet 1/4" ISO 228.
- Max. pressure: 10 bar.
- Operating media temperature: from -10°C to +80°C.
- Ambient temperature: from -10°C to +50°C.

#### Micro solenoid valve

- This solenoid valve is connected by a joint which fits directly to the actuator air intake, without other fittings or fixing screws.
- 3/2 solenoid valve, with solenoid available in the following voltages: 24-110-220V AC; 12-24V DC.
- Starting input power - A.C.: 9 VA.
- Full-working input power - D.C.: 5 W.
- Full-working input power - A.C.: 6 VA.
- Supply voltage tolerances: +/- 10%.
- Copper wire insulation: H-class.
- Coil insulation: F-class.
- Protection with connector: IP65.
- Electric connection: PG 9 any orientation acceptable 360°.
- Pneumatic connections: 1/8" ISO 228 any orientation acceptable 360°.
- Max. pressure: 10 bar.
- Operating media temperature: from -10°C to +50°C.
- Ambient temperature: from -10°C to +50°C.
- ø Bore 1,3 mm.

#### LIMIT SWITCH

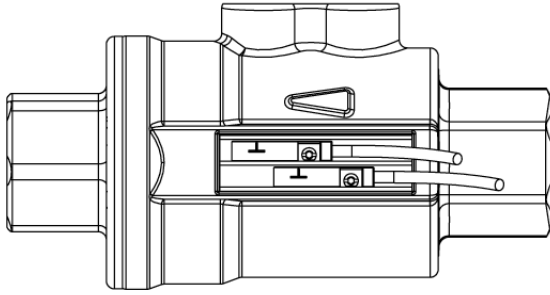

VIP can be provided with inductive limit switch (magnetic contact) and signal LED. Limit switches can be easily mounted in the integrated slots and fixed with a screw. Since the magnets are situated inside the valve, they must be mounted while assembling the VIP and not afterwards. For this reason, in case needed, **magnet must be requested at VIP order phase**. The maximum fluid temperature must be lower than the maximum temperature supported by the limit switch.

### DATOS TÉCNICOS FINAL DE CARRERA

Modelo eléctrico		REED (PNP/NPN)	REED (PNP)		HALL (PNP)		HALL (PNP)	
Tipo de contacto		N.O.	N.O.		N.O.		N.O.	
Tensión de alimentación	V	5-120 AC/DC	5-50 AC/DC		10-30 DC		10-30 DC	
Capacidad permanente de corriente de la salida de conmutación CA	mA	100	350		-		-	
Capacidad permanente de corriente de la salida de conmutación CC	mA	100	500		100		100	
Grado de protección		IP 67	IP 67		IP 69K		IP 67	
Temperatura ambiente	°C	-25/70	-25/+70		-25/+85		-25/+60	
	°F	-13÷158	-13 ÷ +158		-13/185		-13/+140	
Número de cables		2	3		3		3	
Longitud del cable	m	2	2	0,3	2	0,3	2	0,3
	ft	6,56	6,56	1	6,56	1	6,56	1
Conexión		Directa	Directa	M12	Directa	M12	Directa	M12
Categoría Atex		-	-		-		II 3D Ex tc IIIC T Dc C	
Certificados		CE/UKCA/UL/EAC/CCC	CE/UKCA/UL/EAC/CCC		CE/UKCA/UL/EAC		CE/UKCA/UL/EAC	
Códigos		<b>FM7B7200</b>	<b>FM7B9200</b>	<b>FM7B9112</b>	<b>FM7C3200</b>	<b>FM7C3112</b>	<b>FM7A3200</b>	<b>FM7A3112</b>
Material		PA / Inox						

#### Limit switch wiring

REED (2 fili / 2 wires)

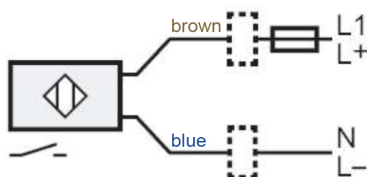

REED (3 fili / 3 wires)

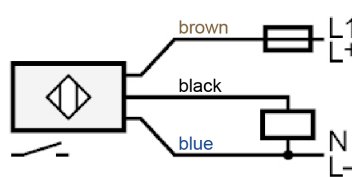

HALL (3 fili / 3 wires)

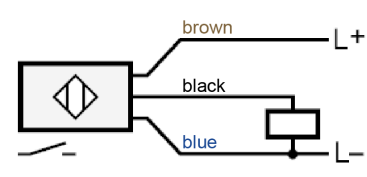

#### NAMUR PLATE ADAPTER

# VIP

## DN10 ÷ DN50

### KBNJ0001

The maximum fluid temperature must be lower than the maximum temperature supported by the solenoid valve.

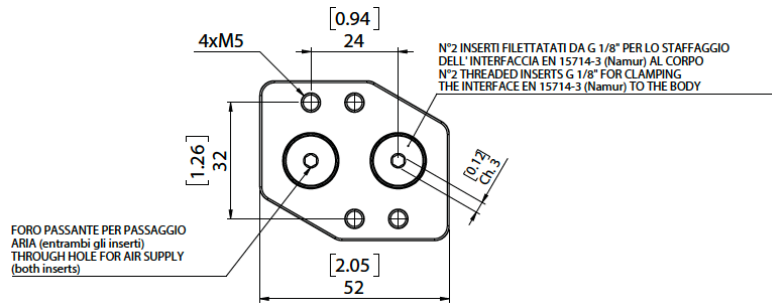

## documentos

### Certificati

[PED](#)

[ATEX - Pneumatic Valves](#)

### Istruzioni

[ISTRUZIONI ATEX 8\\_0489-02](#)

[ISTRUZIONI USO 8\\_1607 - VIP new model](#)

[UIT00A70AOX - Istruzioni Uso Ossigeno VIP](#)