

Item D122 brass ball valve

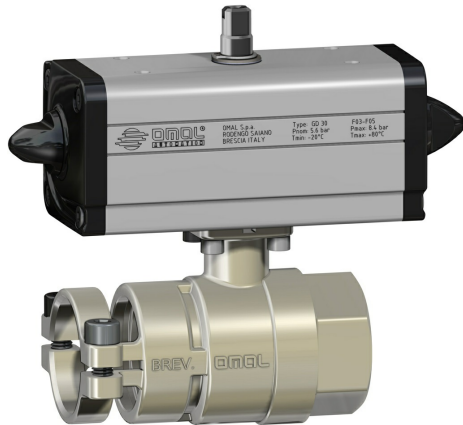

Macro Ball valves

Category Other brass ball valves

Ball valve with quick coupling for zootechnical use - full bore

features

GENERAL FEATURES:

- Operating Temperature: from -15°C to +100°C
- Operating Pressure: 10 bar max at ambient temperature
- Media: air, water, fluids for pigs feeding
- Application: Zootechnical equipments
- Threaded ends: female UNI/ISO 228/1; quick coupling with locking by screws (patented system)

ON REQUEST:

- For other applications, please contact our sales department.

dimensions

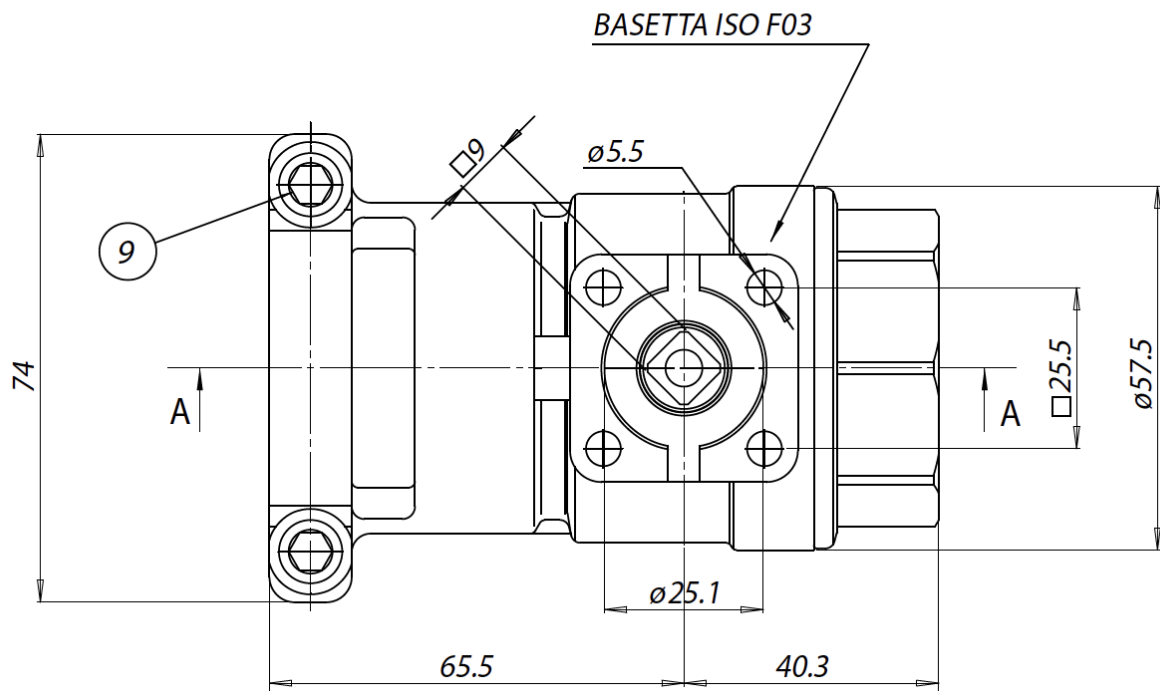
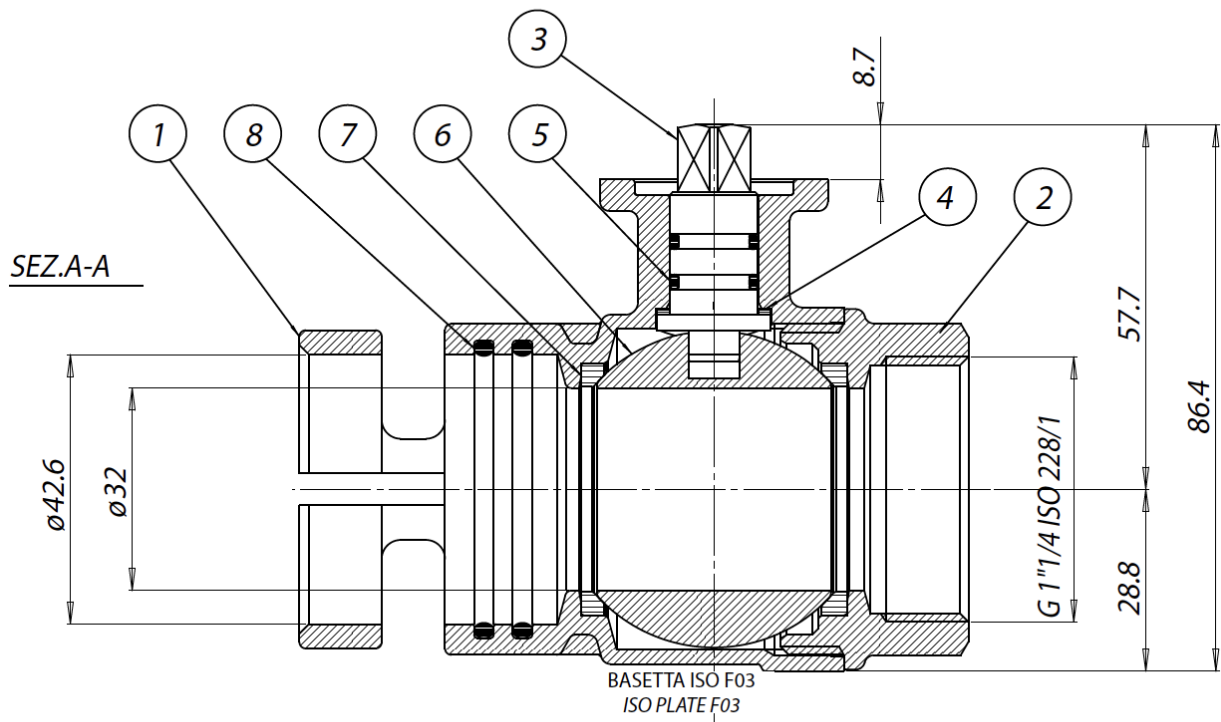

DIMENSIONS		
Valve	Female threaded ends - quick coupling (F/R)	V122N997
Nominal Diameter	mm.	32
Female threaded sleeve	Gas	1"1/4
Nominal bore øP	mm.	32
Weight	Kg	1,7

materials

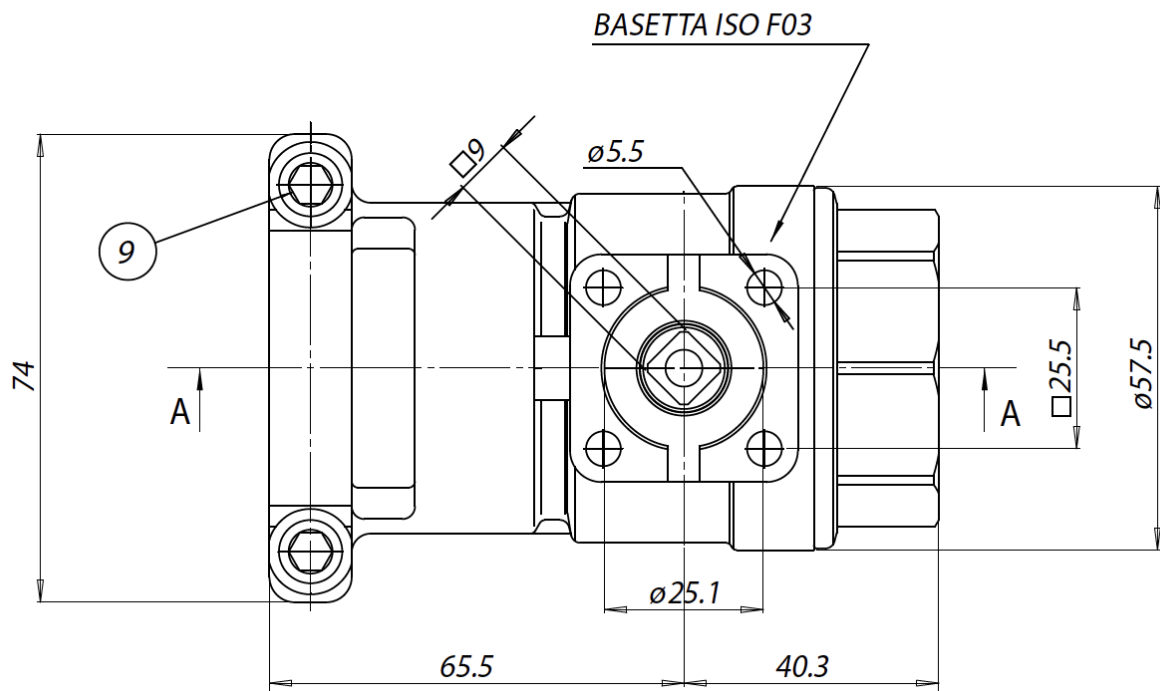
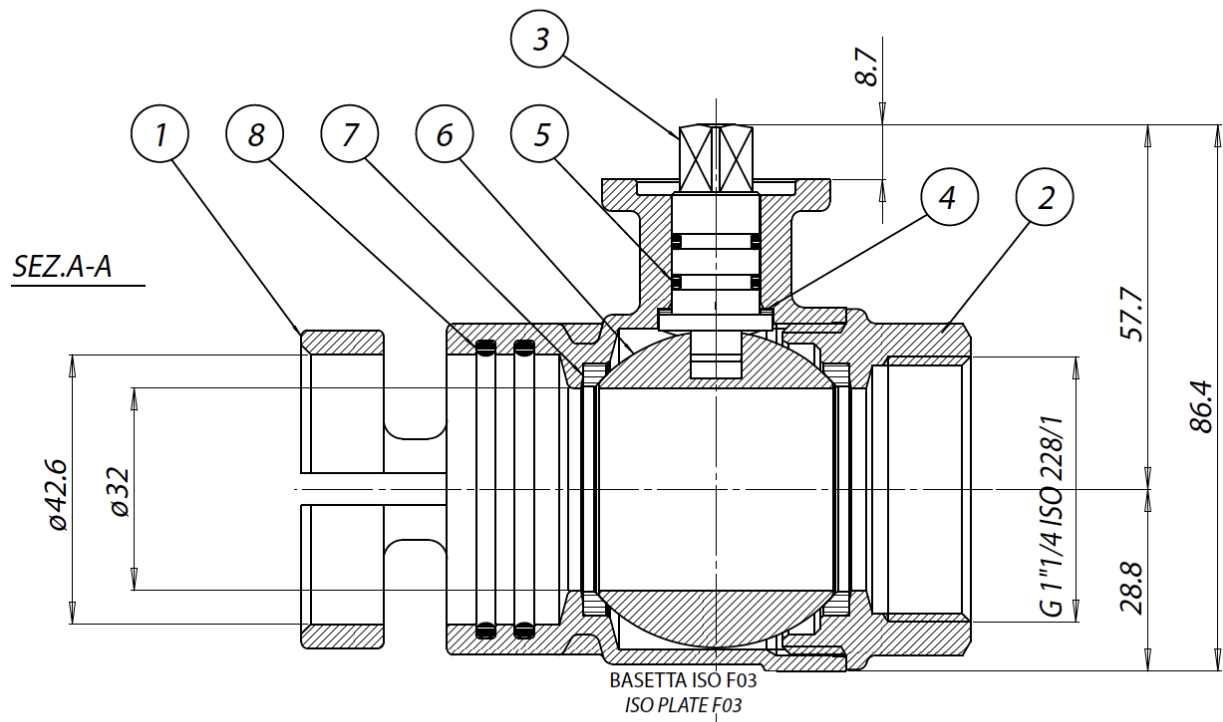

MATERIALS				
1	Body with quick coupling *	Brass	Nickel plated	EN 12164 CW617N
2	Female threaded sleeve *	Brass	Nickel plated	EN 12164 CW617N
3	Shaft	Brass		EN 12164 CW614N
4	Antifriction disc	P.T.F.E.		
5	Stem o-ring 1,78x11,11 (OR114)	NBR		
6	Ball	Brass chromium plated		EN 12164 CW614N
7	Seats	P.T.F.E.		
8	O-ring 2,62x42,52 (OR3168)	NBR		
9	Screws M8x20	304 S.S.		
* Surface treatment: bright nickel plating				