

Warning: filectime(): stat failed for /var/www/vhost/www.omal.it/htdocs/https://www.omal.it./FilesProdotti/34-Certificate-202029301-OMAL-AttuatoriSRSRNDADAN.pdf in /var/www/vhost/www.omal.it/htdocs/prodotto-printable.php on line 65

AGO - SR 60 PSI ÷ 4,2 bar

Macro Pneumatic actuators

Category AGO - Special version on request



benefits

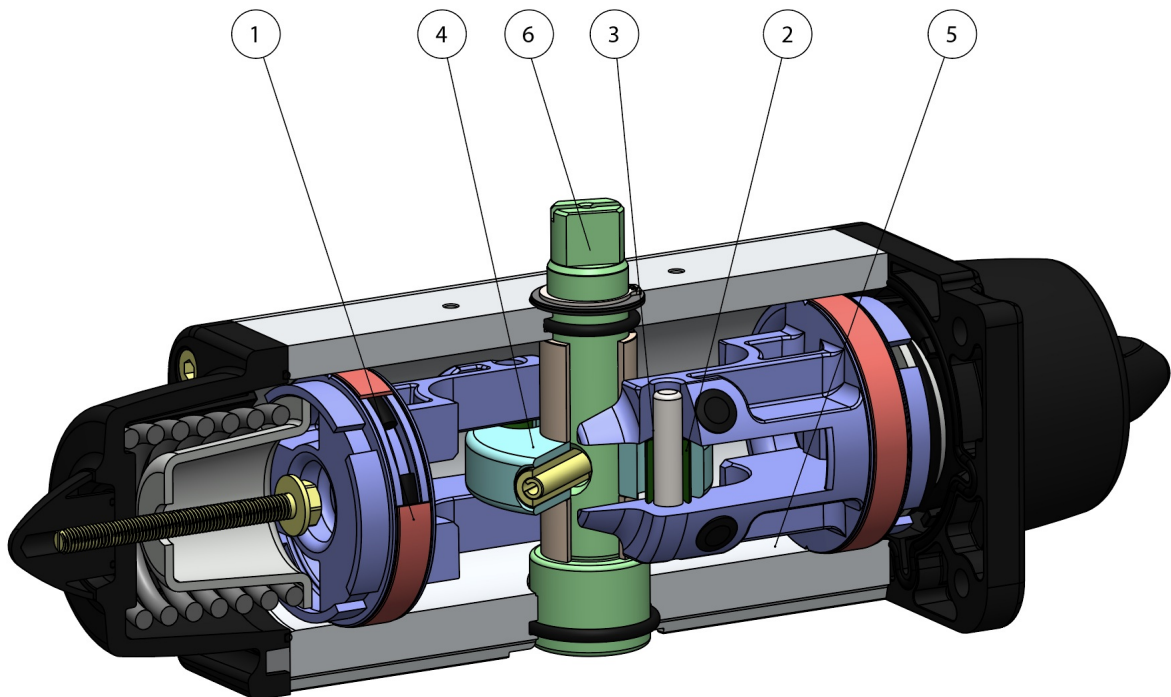

1. Energized and self-lubricated strips

Less friction between piston and cylinder

It prevents the bonding of the seal to the cylinder even after long periods of inactivity

2. Slots, bushes and pins made by steel with hardness higher than 50 HRC

Higher resistance to the forces inside the actuator

3. Rolling friction between piston and slot

Less friction

4. Scotch yoke with rolling friction (transforming rotary motion into linear motion using piston and shaft without teeth/gears)

Reduced friction between piston and shaft with consequently less wear on the relevant parts

Empowered Breakaway Torque (BTO & BTC)

Smaller volume/size than rack and pinion actuators (with the same torque) therefore less space required for installation

Less weight than the rack and pinion (-30% kg / Nm), with consequent savings on the construction sizing of the plant/equipment

Lower air consumption compared to the rack and pinion actuators (-40% air cm³/Nm for Double Acting and -20% air cm³/Nm for Spring Return) therefore less load on the compressor or the possibility of using a smaller compressor's size.

5. Rolled cylinder

Less wear of the energized ties thanks to the low roughness of the surface

6. Stainless Steel shaft

Higher corrosion resistance

From sizes bigger than DAN15, NAMUR interface for solenoid valve is already integrated

No need for extra plate.

100% in- house manufacturing process technology

Maximum control and accuracy in all the stages of the manufacturing process

ATEX Certificate

Installation is allowed in a potential explosive environment

Up to SIL 3 Certified

Guarantee of the high level of functional safety.

specifications

WORKING PLANE PNEUMATIC ACTUATOR "SR" TYPE

SCHEMA FUNZIONAMENTO ATTUATORE PNEUMATICO AGO "SR"
WORKING PLANE PNEUMATIC ACTUATOR AGO "SR" TYPE

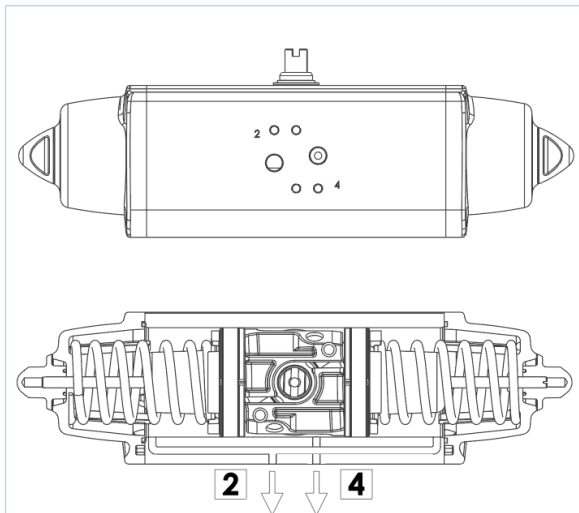

SCHEMA DI FUNZIONAMENTO

Senza pressione di alimentazione, nella versione semplice effetto, l'attuatore torna automaticamente in posizione di riposo compiendo una rotazione oraria e la posizione finale è quella rappresentata nel disegno. Sul foro 2 è consigliato montare un filtrino onde evitare che polvere o particelle solide possano entrare nella camera del cilindro senza tuttavia impedire il passaggio dell'aria.

WORKING PLANE

Without air supply, the spring return actuator returns to its resting position, rotating in a clockwise direction. The drawing shows its final position. We assembling a small filter on the air connection 2 to prevent dust and particles into the cylinder chamber without, however, preventing the passage of air.

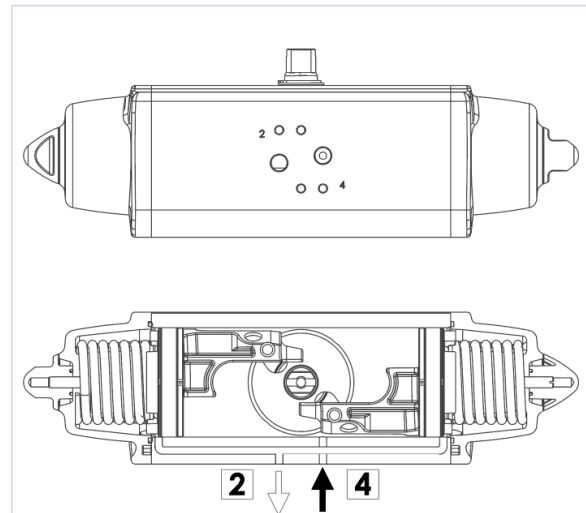

SCHEMA DI FUNZIONAMENTO

Immettendo aria nel foro 4 di alimentazione, i pistoni si muovono verso l'esterno comprimendo le molle, si ha una rotazione antioraria e la posizione finale è quella rappresentata nel disegno.

WORKING PLANE

Supplying air through the air connection 4, the pistons move outwards pressing the spring. An anticlockwise rotation takes place and the final position is shown above.

ATTUATORE REGOLABILE-ISTRUZIONI PER L' UTILIZZO ACTUATOR WITH STROKE ADJUSTMENT-INSTRUCTIONS

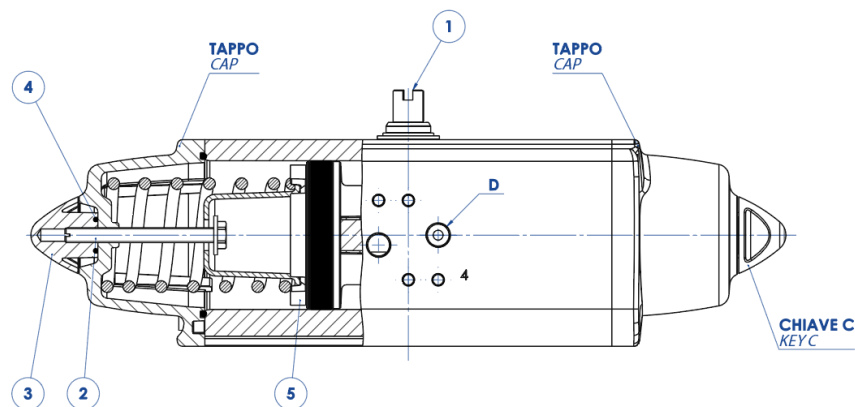

- A)** Verificare che le molle siano in posizione di riposo osservando la chiave dell'albero (part. n°1) come da disegno e controllando che nel foro "D" non ci sia pressione.
- B)** Togliere i controdadi (part. n°3) agendo sulla chiave C.
- C)** Con un cacciavite avvitare le viti (part. n°2) in senso orario ed effettuare la limitazione di corsa desiderata.
- N.B.** La corsa può essere limitata per un massimo di 10° da 80° a 90°
- D)** Immettere aria nel foro "D" e verificare che entrambe le viti (part. n°2) siano a battuta contro i pistoni (part. n°5).
- E)** Bloccare i controdadi (part. n°3) muniti di O-ring (part. n°4) per la tenuta tra controdado, tappo e vite.

N.B. queste spiegazioni sono indicative, per le istruzioni operative, vedere il manuale.

- A)** The springs must be at rest position, the shaft (part. 1) must be as shown in the drawing. Air connection D must not be supplied with air.
- B)** Remove the counter-nuts (part. 3), acting on C key.
- C)** By means of a screwdriver turn screws (part. 2) in a clockwise direction until you obtain the requested end-stroke regulation.
- Note:** maximum adjusting stroke 10°, ranging from 80° to 90°.
- D)** Supply connection D with air pressure and check that both adjusting screws (part. 2) stop the pistons (part. 5).
- E)** Screw the counter-nuts (part. 3) and their O-ring (part. 4) to keep nut and cap tight.

N.B. these explanations are indicative, for operating instructions, see the manual.



OMAL S.p.A. Società Benefit

Headquarters: Via Ponte Nuovo 11, Rodengo Saiano (Brescia) Italy

Production site: Via Brognolo 12, Passirano (Brescia) Italy

Ph +39 0308900145 Fax +39 0308900423

documents

Certificati

SIL EN 61508 - Actuators: SR, SRN, DA, DAN