

Warning: filectime(): stat failed for /var/www/vhost/www.omal.it/htdocs/https://www.omal.it./FilesProdotti/34-Certificate-202029301-OMAL-AttuatoriSRSRNDADAN.pdf in /var/www/vhost/www.omal.it/htdocs/prodotto-printable.php on line 65

## AGO - SR 40 PSI ÷ 2,8 bar

Macro Pneumatic actuators

Category AGO - Special version on request



### benefits

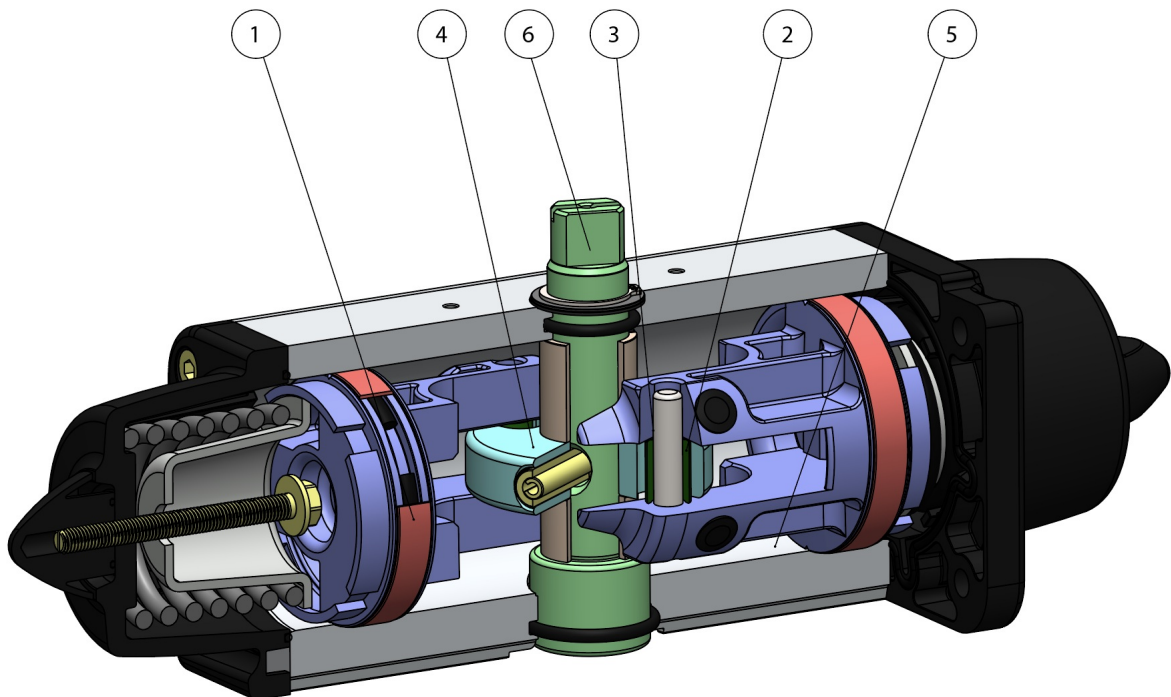

**1. Energized and self-lubricated strips**

Less friction between piston and cylinder

It prevents the bonding of the seal to the cylinder even after long periods of inactivity

**2. Slots, bushes and pins made by steel with hardness higher than 50 HRC**

Higher resistance to the forces inside the actuator

**3. Rolling friction between piston and slot**

Less friction

**4. Scotch yoke with rolling friction (transforming rotary motion into linear motion using piston and shaft without teeth/gears)**

Reduced friction between piston and shaft with consequently less wear on the relevant parts

Empowered Breakaway Torque (BTO & BTC)

Smaller volume/size than rack and pinion actuators (with the same torque) therefore less space required for installation

Less weight than the rack and pinion (-30% kg / Nm), with consequent savings on the construction sizing of the plant/equipment

Lower air consumption compared to the rack and pinion actuators (-40% air cm<sup>3</sup>/Nm for Double Acting and -20% air cm<sup>3</sup>/Nm for Spring Return) therefore less load on the compressor or the possibility of using a smaller compressor's size.

**5. Rolled cylinder**

Less wear of the energized ties thanks to the low roughness of the surface

**6. Stainless Steel shaft**

Higher corrosion resistance

**From sizes bigger than DAN15, NAMUR interface for solenoid valve is already integrated**

No need for extra plate.

**100% in- house manufacturing process technology**

Maximum control and accuracy in all the stages of the manufacturing process

**ATEX Certificate**

Installation is allowed in a potential explosive environment

**Up to SIL 3 Certified**

Guarantee of the high level of functional safety.

specifications

WORKING PLANE PNEUMATIC ACTUATOR "SR" TYPE

**SCHEMA FUNZIONAMENTO ATTUATORE PNEUMATICO AGO "SR"**  
**WORKING PLANE PNEUMATIC ACTUATOR AGO "SR" TYPE**

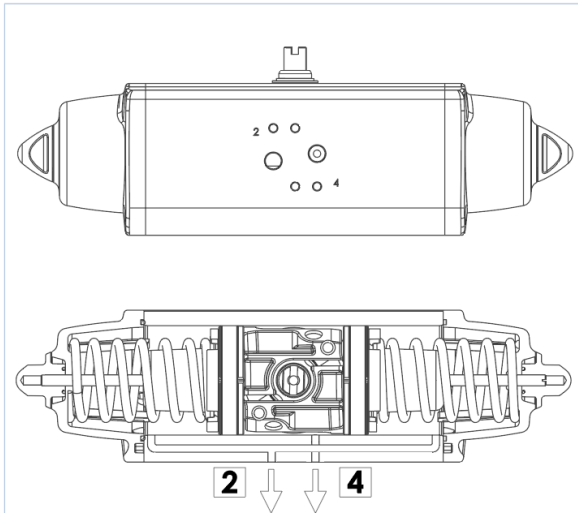

**SCHEMA DI FUNZIONAMENTO**

Senza pressione di alimentazione, nella versione semplice effetto, l'attuatore torna automaticamente in posizione di riposo compiendo una rotazione oraria e la posizione finale è quella rappresentata nel disegno. Sul foro 2 è consigliato montare un filtrino onde evitare che polvere o particelle solide possano entrare nella camera del cilindro senza tuttavia impedire il passaggio dell'aria.

**WORKING PLANE**

Without air supply, the spring return actuator returns to its resting position, rotating in a clockwise direction. The drawing shows its final position. We assembling a small filter on the air connection 2 to prevent dust and particles into the cylinder chamber without, however, preventing the passage of air.

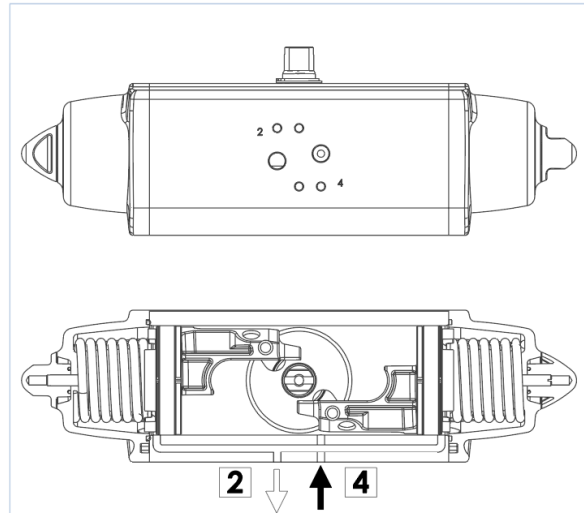

**SCHEMA DI FUNZIONAMENTO**

Immettendo aria nel foro 4 di alimentazione, i pistoni si muovono verso l'esterno comprimendo le molle, si ha una rotazione antioraria e la posizione finale è quella rappresentata nel disegno.

**WORKING PLANE**

Supplying air through the air connection 4, the pistons move outwards pressing the spring. An anticlockwise rotation takes place and the final position is shown above.

**ATTUATORE REGOLABILE-ISTRUZIONI PER L' UTILIZZO ACTUATOR WITH STROKE ADJUSTMENT-INSTRUCTIONS**

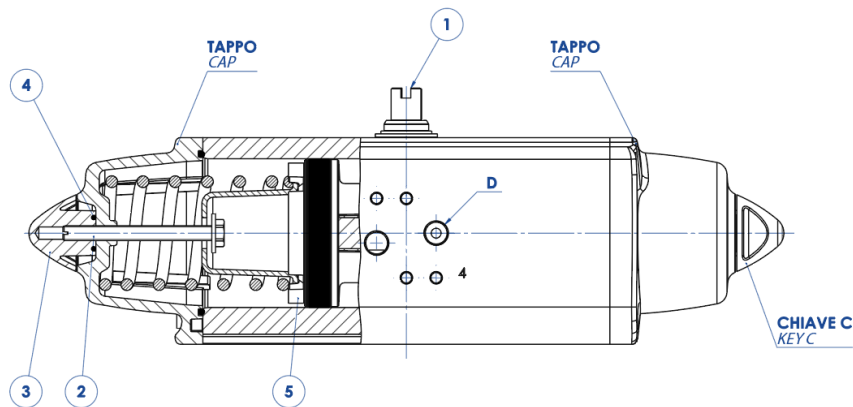

- A)** Verificare che le molle siano in posizione di riposo osservando la chiave dell'albero (part. n°1) come da disegno e controllando che nel foro "D" non ci sia pressione.
- B)** Togliere i controdadi (part. n°3) agendo sulla chiave C.
- C)** Con un cacciavite avvitare le viti (part. n°2) in senso orario ed effettuare la limitazione di corsa desiderata.
- N.B.** La corsa può essere limitata per un massimo di 10° da 80° a 90°
- D)** Immettere aria nel foro "D" e verificare che entrambe le viti (part. n°2) siano a battuta contro i pistoni (part. n°5).
- E)** Bloccare i controdadi (part. n°3) muniti di O-ring (part. n°4) per la tenuta tra controdado, tappo e vite.

N.B. queste spiegazioni sono indicative, per le istruzioni operative, vedere il manuale.

- A)** The springs must be at rest position, the shaft (part. 1) must be as shown in the drawing. Air connection D must not be supplied with air.
- B)** Remove the counter-nuts (part. 3), acting on C key.
- C)** By means of a screwdriver turn screws (part. 2) in a clockwise direction until you obtain the requested end-stroke regulation.
- Note:** maximum adjusting stroke 10°, ranging from 80° to 90°.
- D)** Supply connection D with air pressure and check that both adjusting screws (part. 2) stop the pistons (part. 5).
- E)** Screw the counter-nuts (part. 3) and their O-ring (part. 4) to keep nut and cap tight.

N.B. these explanations are indicative, for operating instructions, see the manual.



**OMAL S.p.A. Società Benefit**

Headquarters: Via Ponte Nuovo 11, Rodengo Saiano (Brescia) Italy

Production site: Via Brognolo 12, Passirano (Brescia) Italy

Ph +39 0308900145 Fax +39 0308900423

## documents

### Certificati

SIL EN 61508 - Actuators: SR, SRN, DA, DAN