

Warning: filectime(): stat failed for
/var/www/vhost/www.omal.it/htdocs/https://www.omal.it./FilesProdotti/RICEVUTADEPOSITOF.T.ATEXN.AP-18.pdf in
/var/www/vhost/www.omal.it/htdocs/prodotto-printable.php on line 65

Warning: filectime(): stat failed for /var/www/vhost/www.omal.it/htdocs/https://www.omal.it./FilesProdotti/34-Certificate-202029301-OMAL-AttuatoriSRSRNDADAN.pdf in /var/www/vhost/www.omal.it/htdocs/prodotto-printable.php on line 65

Warning: filectime(): stat failed for /var/www/vhost/www.omal.it/htdocs/https://www.omal.it./FilesProdotti/TAP00001G5-revision1.pdf in /var/www/vhost/www.omal.it/htdocs/prodotto-printable.php on line 65

Warning: filectime(): stat failed for /var/www/vhost/www.omal.it/htdocs/https://www.omal.it./FilesProdotti/UITG0G01-UITG0G01ATX-FogliettoIstruzioniAttuatoriAGO.pdf in /var/www/vhost/www.omal.it/htdocs/prodotto-printable.php on line 65

Warning: filectime(): stat failed for
/var/www/vhost/www.omal.it/htdocs/https://www.omal.it./PdfProdotti/116/Istruzioni/ISTRUZIONI USO 8_0842/8_0842-Istr_Attuatori_Pneumatici_Omal-03-18.pdf in /var/www/vhost/www.omal.it/htdocs/prodotto-printable.php on line 65

Warning: filectime(): stat failed for /var/www/vhost/www.omal.it/htdocs/https://www.omal.it./FilesProdotti/UMA800081B-IT-ATTUATOREPNEUMATICODA15-DAN1920-SR15-SRN960-DD-DAV-SRV-07-21.pdf in /var/www/vhost/www.omal.it/htdocs/prodotto-printable.php on line 65

AGO CF8M - SR type inox precision casting CF8M

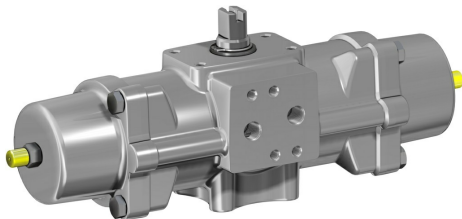

Macro Pneumatic actuators

Category AGO CF8M - Inox precision casting CF8M actuators

benefits

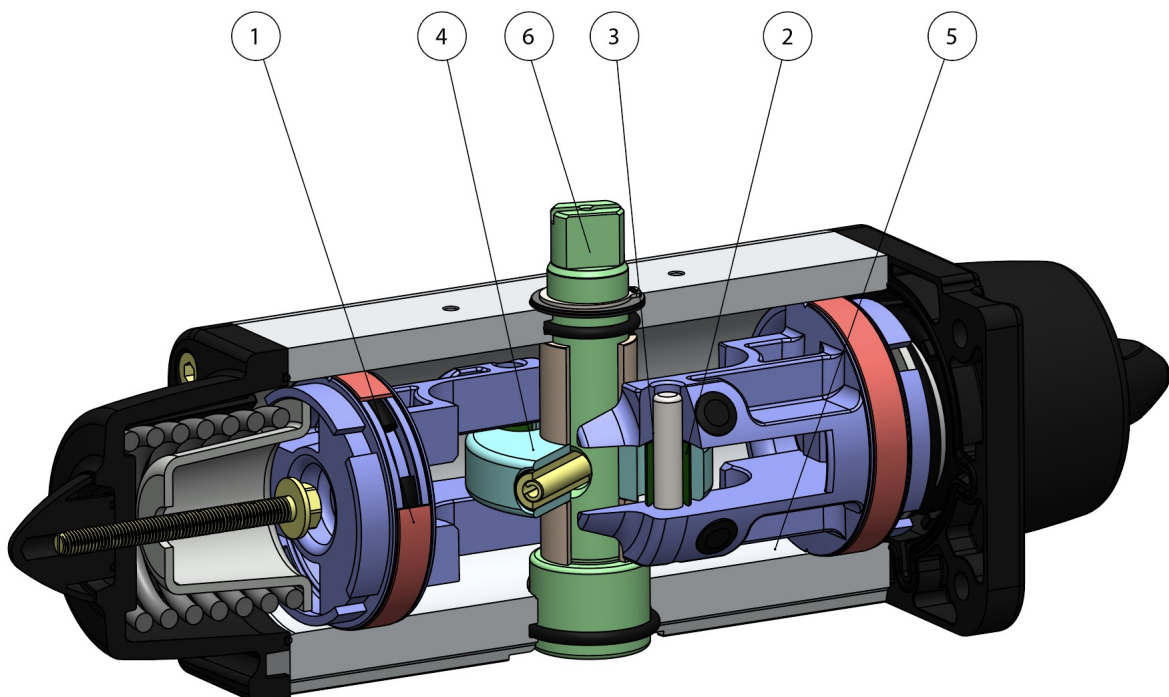

1. Energized and self-lubricated strips

Less friction between piston and cylinder

It prevents the bonding of the seal to the cylinder even after long periods of inactivity

2. Slots, bushes and pins made by steel with hardness higher than 50 HRC

Higher resistance to the forces inside the actuator

3. Rolling friction between piston and slot

Less friction

4. Scotch yoke with rolling friction (transforming rotary motion into linear motion using piston and shaft without teeth/gears)

Reduced friction between piston and shaft with consequently less wear on the relevant parts

Empowered Breakaway Torque (BTO & BTC)

Smaller volume/size than rack and pinion actuators (with the same torque) therefore less space required for installation

Less weight than the rack and pinion (-30% kg / Nm), with consequent savings on the construction sizing of the plant/equipment

Lower air consumption compared to the rack and pinion actuators (-40% air cm³/Nm for Double Acting and -20% air cm³/Nm for Spring Return) therefore less load on the compressor or the possibility of using a smaller compressor's size.

5. Rolled cylinder

Less wear of the energized ties thanks to the low roughness of the surface

6. Stainless Steel shaft

Higher corrosion resistance

From sizes bigger than DAN15, NAMUR interface for solenoid valve is already integrated.

No need for extra plate.

100% in- house manufacturing process technology

Maximum control and accuracy in all the stages of the manufacturing process

ATEX Certificate

Installation is allowed in a potential explosive environment

Up to SIL 3 Certified

Guarantee of the high level of functional safety.

features

TECHNICAL FEATURES

Torque from 15 Nm to 240 Nm.

Mounting flange according to ISO 5211; F03 - F05 - F07 - F10.

In compliance with EN 15714-3.

Rotation angle: 92° (-1°, +91°)

Torque: the return torque depends on spring action only notwithstanding the air supply.

The spring is provided in four different sizes (see table - general catalogue pneumatic actuator SR). The code numbers after the letters SR, always correspond to the breakaway torque in Nm by 5,6 bar air supply. The actuator automatic closing takes place in clockwise direction by means of its springs.

Sizes from SR 30 direct connection with NAMUR solenoid valve.

Size SR15 can be provided with NAMUR plate on request ATEX version in conformity with directive 2014/34/EU. Please add YX at the end of the code for ATEX version.

WORKING CONDITION

Temperature: from -20°C to +80°C.

Air supply: 5,6 bar; maximum 8,4 bar.

Actuating media: filtered dry compressed air, not necessarily lubricated. In case of lubricated air, either non detergent oil, NBR compatible oil, must be used.

dimensions

SR 15

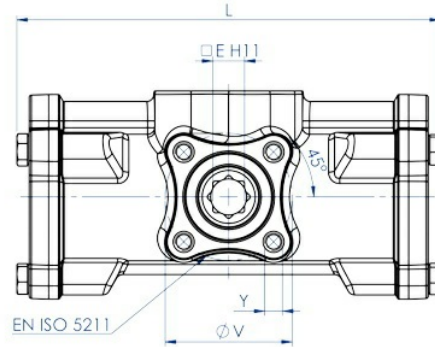

Interfaccia EN 15714-3 (Namur) a richiesta
 EN 15714-3 (Namur) interface on request

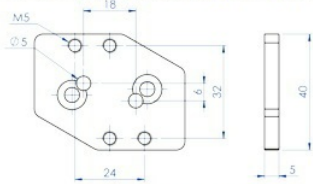

Optional Code KBNI4015

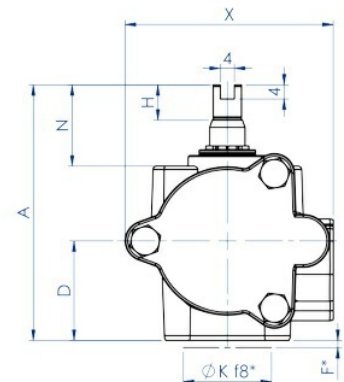
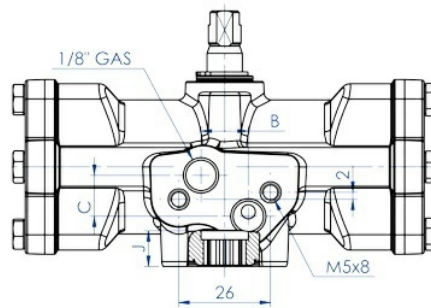

*Anello di centraggio
 Centering ring

Interfaccia EN 15714-3 (Namur) a richiesta
 EN 15714-3 (Namur) interface on request

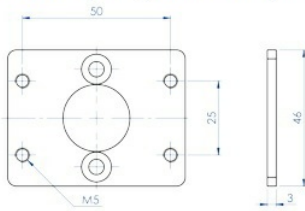

Optional Code KBVI4015

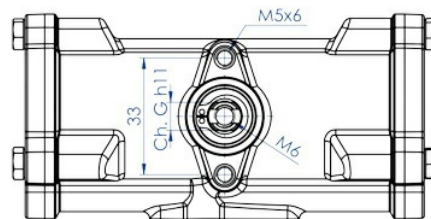

SR 30 ÷ SR 240

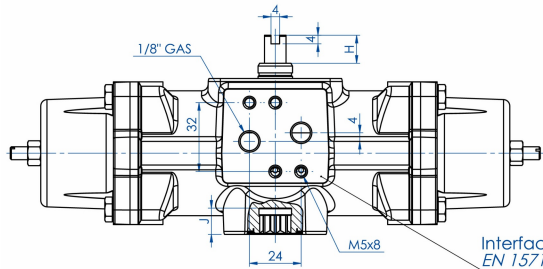
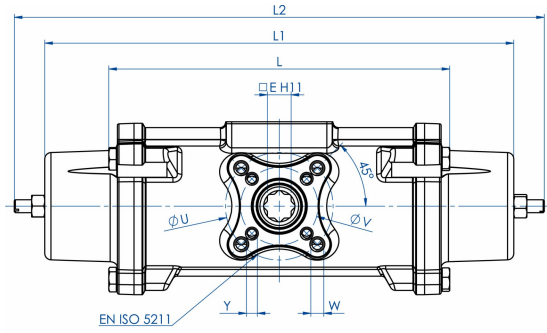

Interfaccia EN 15714-3 (Namur)
EN 15714-3 (Namur) interface

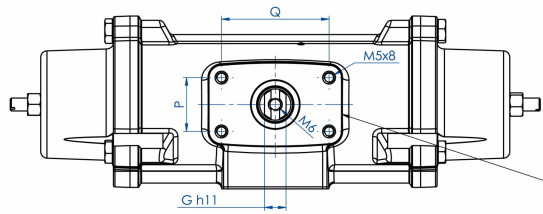
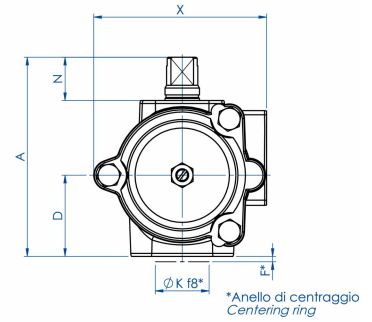

Interfaccia per accessori
EN 15714-3 (VDI/VDE 3845)
Accessories interface
EN 15714-3 (VDI/VDE 3845)

DATA SHEET

Code	SR015516S	SR030516S	SR060516S	SR120516S	SR240516S
Spare seals	KGXI0114	KGXI0116	KGXI0118	KGXI0120	KGXI0122
Size	SR 15 F03	SR 30 F03-F05	SR 60 F05-F07	SR 120 F05-F07	SR 240 F07-F10
L mm.	134,6	158,4	192,9	246,8	298,4
L1 mm.	194,2	217,9	287,5	341,2	421
L2 mm.	224	246,2	316,5	376,2	463,9
A mm.	80,4	92,5	116,5	136,4	160
D mm.	32,7	37,7	46,2	56,2	68
E mm.	9	11	14	17	22
F mm.	2	2	3	3	3
Ch. G mm.	9	10	12	15	19
H mm.	10	13	13	17	19
N mm.	23	20	30	30	30
X mm.	68	80,3	94,4	117	139,7
J mm.	10,2	12,2	16,3	19,3	24,3
ØK mm.	25	25	35	35	55
Q mm.	50	50	80	80	80
P mm.	25	25	30	30	30
ØU mm.	-	50	70	70	102
ØV mm.	36	36	50	50	70
Y x prof. depth mm.	M5x9	M5x9	M6x11	M6x11	M8x13
W x prof. depth mm.	-	M6x11	M8x15	M8x13	M10x22
air dm ³ /cycle	0,086	0,16	0,33	0,7	1,38
weight Kg.	1,6	2,4	4,5	7,6	12,9

materials

CASTING CF8M SPRING RETURN PNEUMATIC ACTUATOR COMPONENTS SIZE: SR15

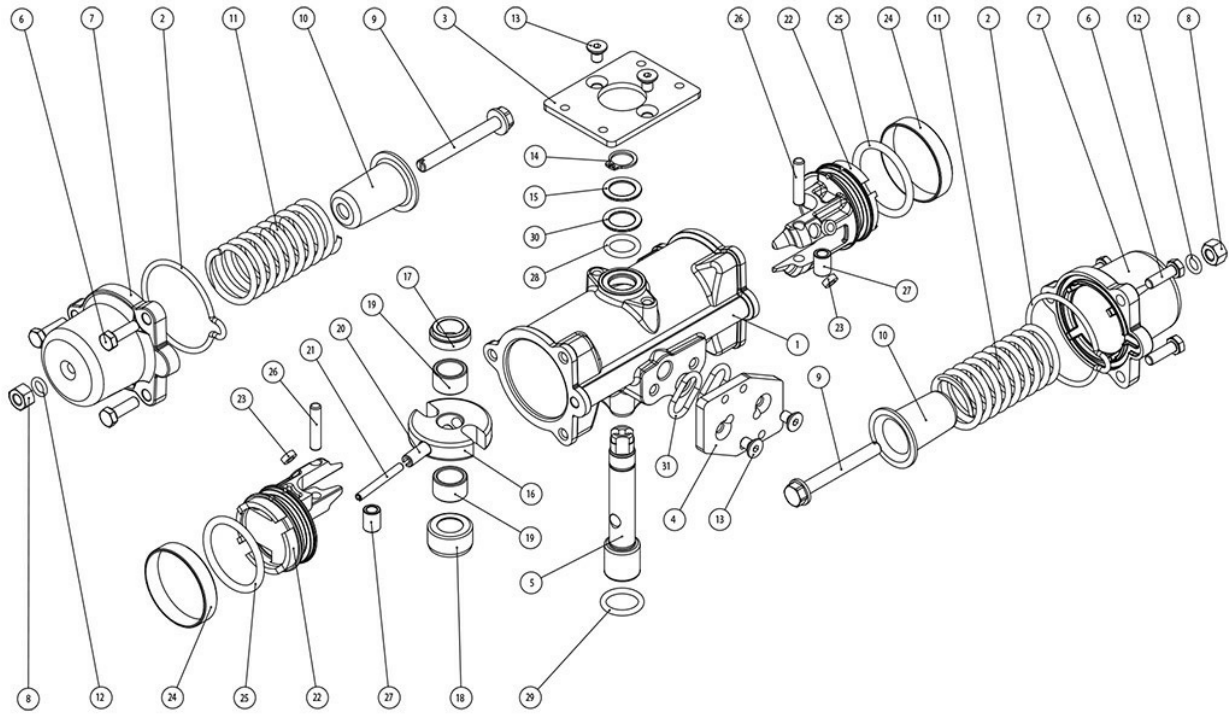

MATERIALS SR15

Pos	Denomination	Q.ty	Material
1	Cylinder	1	Stainless steel
2*	Cap o-ring	2	Nitrilic rubber
3	Plate (optional)	1	Stainless steel
4	NAMUR plate	1	Stainless steel
5	Shaft	1	Stainless steel
6	Screw	6	Stainless steel
7	Cap	2	Stainless steel
8	Nut	2	Stainless steel
9	Spring loading screw	2	Stainless steel
10	Spring cap	2	Steel alloy
11	Spring	2	Steel alloy
12*	O-ring	2	Nitrilic rubber
13	Screw	4	Stainless steel
14	Seeger	1	Stainless steel
15	Washer	1	Stainless steel
16	Scotch yoke	1	Steel alloy
17	Upper shaft support	1	Acetalic resin
18	Lower shaft support	1	Acetalic resin
19	Support bush	2	Acetalic resin
20	External elastic pin of the yoke	1	Steel alloy
21	Internal elastic pin of the yoke	1	Steel alloy
22	Piston	2	Aluminium alloy
23*	Piston's support	4	P.T.F.E. carbo-graphite filled
24*	Dynamic seal	2	Polyurethane
25*	Piston o-ring	2	Nitrilic rubber
26	Rotative sleeve	2	Steel alloy
27	Bush	2	Steel alloy
28	O-ring	1	FKM
29	O-ring	1	FKM
30	External support ring	1	Acetalic resin
31	NAMUR o-ring	2	Nitrilic rubber
* Components of spare part kit			

CASTING CF8M SPRING RETURN PNEUMATIC ACTUATOR COMPONENTS SIZE: SR30-SR240

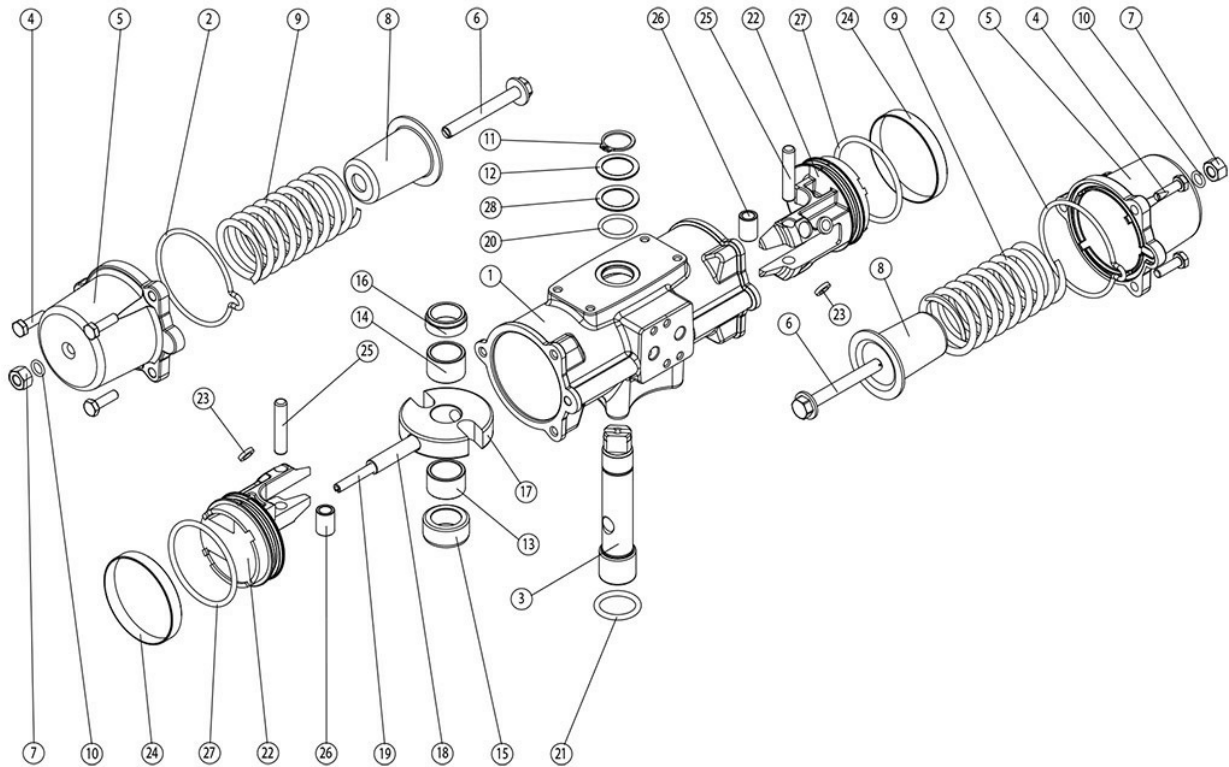

MATERIALS SR30-SR240

Pos	Denomination	Q.ty	Material
1	Cylinder	1	Stainless steel
2*	Cap o-ring	2	Nitrilic rubber
3	Shaft	1	Stainless steel
4	Screw	6	Stainless steel
5	Cap	2	Stainless steel
6	Spring loading screw	2	Stainless steel
7	Nut	2	Stainless steel
8	Spring cap	2	Steel alloy
9	Spring	2	Steel alloy
10*	O-ring	2	Nitrilic rubber
11	Seeger	1	Steel alloy
12	Washer	1	Steel alloy
13	Lower support bush	1	Acetalic resin
14	Upper support bush	1	Acetalic resin
15	Lower shaft support	1	Acetalic resin
16	Upper shaft support	1	Acetalic resin
17	Scotch yoke	1	Steel alloy
18	External elastic pin of yoke	1	Steel alloy
19	Internal elastic pin of yoke	1	Steel alloy
20	O-ring upper sealing shaft	1	FKM
21	O-ring low sealing shaft	1	FKM
22	Piston	2	Aluminium alloy
23*	Piston's support	4	P.T.F.E. carbo-graphite filled
24*	Dynamic seal	2	Polyurethane
25	Rotative sleeve	2	Steel alloy
26	Bush	2	Steel alloy
27*	Piston o-ring	2	Nitrilic rubber
28	External support o-ring	1	Acetalic resin

* Components of spare part kit

specifications

WORKING PLANE PNEUMATIC ACTUATOR "SR" TYPE

SCHEMA FUNZIONAMENTO ATTUATORE PNEUMATICO AGO "SR"
WORKING PLANE PNEUMATIC ACTUATOR AGO "SR" TYPE

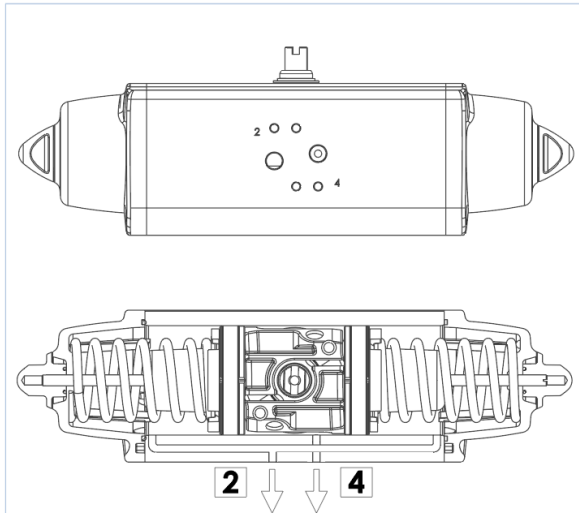

SCHEMA DI FUNZIONAMENTO

Senza pressione di alimentazione, nella versione semplice effetto, l'attuatore torna automaticamente in posizione di riposo compiendo una rotazione oraria e la posizione finale è quella rappresentata nel disegno. Sul foro 2 è consigliato montare un filtrino onde evitare che polvere o particelle solide possano entrare nella camera del cilindro senza tuttavia impedire il passaggio dell'aria.

WORKING PLANE

Without air supply, the spring return actuator returns to its resting position, rotating in a clockwise direction. The drawing shows its final position. We assembling a small filter on the air connection 2 to prevent dust and particles into the cylinder chamber without, however, preventing the passage of air.

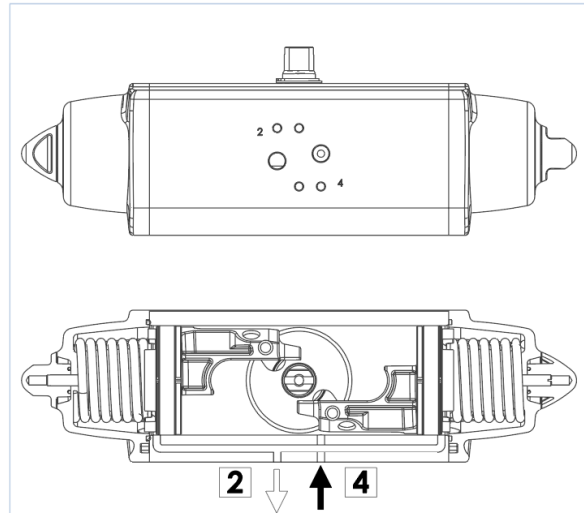

SCHEMA DI FUNZIONAMENTO

Immettendo aria nel foro 4 di alimentazione, i pistoni si muovono verso l'esterno comprimendo le molle, si ha una rotazione antioraria e la posizione finale è quella rappresentata nel disegno.

WORKING PLANE

Supplying air through the air connection 4, the pistons move outwards pressing the spring. An anticlockwise rotation takes place and the final position is shown above.

ATTUATORE REGOLABILE-ISTRUZIONI PER L' UTILIZZO ACTUATOR WITH STROKE ADJUSTMENT-INSTRUCTIONS

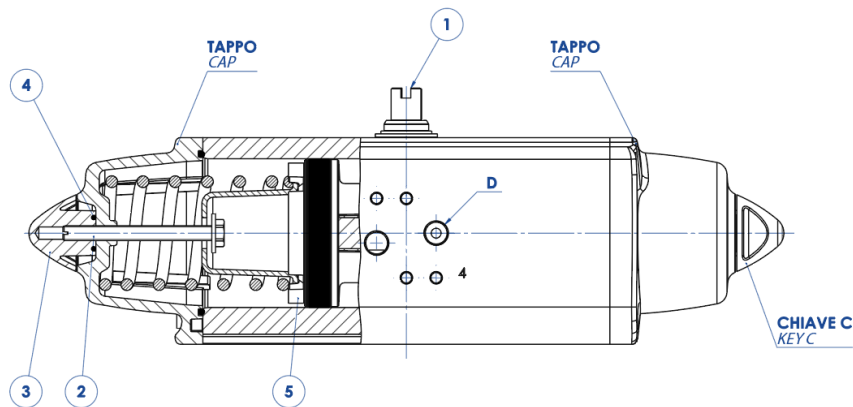

- A)** Verificare che le molle siano in posizione di riposo osservando la chiave dell'albero (part. n°1) come da disegno e controllando che nel foro "D" non ci sia pressione.
- B)** Togliere i controdadi (part. n°3) agendo sulla chiave C.
- C)** Con un cacciavite avvitare le viti (part. n°2) in senso orario ed effettuare la limitazione di corsa desiderata.
- N.B.** La corsa può essere limitata per un massimo di 10° da 80° a 90°
- D)** Immettere aria nel foro "D" e verificare che entrambe le viti (part. n°2) siano a battuta contro i pistoni (part. n°5).
- E)** Bloccare i controdadi (part. n°3) muniti di O-ring (part. n°4) per la tenuta tra controdado, tappo e vite.

N.B. queste spiegazioni sono indicative, per le istruzioni operative, vedere il manuale.

- A)** The springs must be at rest position, the shaft (part. 1) must be as shown in the drawing. Air connection D must not be supplied with air.
- B)** Remove the counter-nuts (part. 3), acting on C key.
- C)** By means of a screwdriver turn screws (part. 2) in a clockwise direction until you obtain the requested end-stroke regulation.
- Note:** maximum adjusting stroke 10°, ranging from 80° to 90°.
- D)** Supply connection D with air pressure and check that both adjusting screws (part. 2) stop the pistons (part. 5).
- E)** Screw the counter-nuts (part. 3) and their O-ring (part. 4) to keep nut and cap tight.

N.B. these explanations are indicative, for operating instructions, see the manual.

documents

Certificati

[ATEX - Pneumatic Actuators](#)

[SIL EN 61508 - Actuators: SR, SRN, DA, DAN](#)

[Type Approval Certificate for Marine and machinery systems and equipment](#)

Istruzioni

[ISTRUZIONI ATEX UITGOG01ATX](#)

[ISTRUZIONI USO 8_0842](#)

Manuali

[MANUALE UMA800081B](#)