

Warning: filectime(): stat failed for
/var/www/vhost/www.omal.it/htdocs/https://www.omal.it./FilesProdotti/RICEVUTADEPOSITOF.T.ATEXN.AP-18.pdf in
/var/www/vhost/www.omal.it/htdocs/prodotto-printable.php on line 65

Warning: filectime(): stat failed for /var/www/vhost/www.omal.it/htdocs/https://www.omal.it./FilesProdotti/34-Certificate-202029301-OMAL-AttuatoriSRSRNDADAN.pdf in /var/www/vhost/www.omal.it/htdocs/prodotto-printable.php on line 65

Warning: filectime(): stat failed for /var/www/vhost/www.omal.it/htdocs/https://www.omal.it./FilesProdotti/TAP00001G5-revision1.pdf in /var/www/vhost/www.omal.it/htdocs/prodotto-printable.php on line 65

Warning: filectime(): stat failed for /var/www/vhost/www.omal.it/htdocs/https://www.omal.it./FilesProdotti/UITG0G01-UITG0G01ATX-FogliettoIstruzioniAttuatoriAGO.pdf in /var/www/vhost/www.omal.it/htdocs/prodotto-printable.php on line 65

Warning: filectime(): stat failed for /var/www/vhost/www.omal.it/htdocs/https://www.omal.it./PdfProdotti/116/Istruzioni/ISTRUZIONI USO 8_0842/8_0842-Istr_Attuatori_Pneumatici_Omal-03-18.pdf in /var/www/vhost/www.omal.it/htdocs/prodotto-printable.php on line 65

Warning: filectime(): stat failed for /var/www/vhost/www.omal.it/htdocs/https://www.omal.it./FilesProdotti/UMA800081B-IT-ATTUATOREPNEUMATICODA15-DAN1920-SR15-SRN960-DD-DAV-SRV-07-21.pdf in /var/www/vhost/www.omal.it/htdocs/prodotto-printable.php on line 65

AGO A105 - DA type carbon steel A105



Macro Pneumatic actuators

Category AGO A105 - Carbon steel A105 actuators

benefits

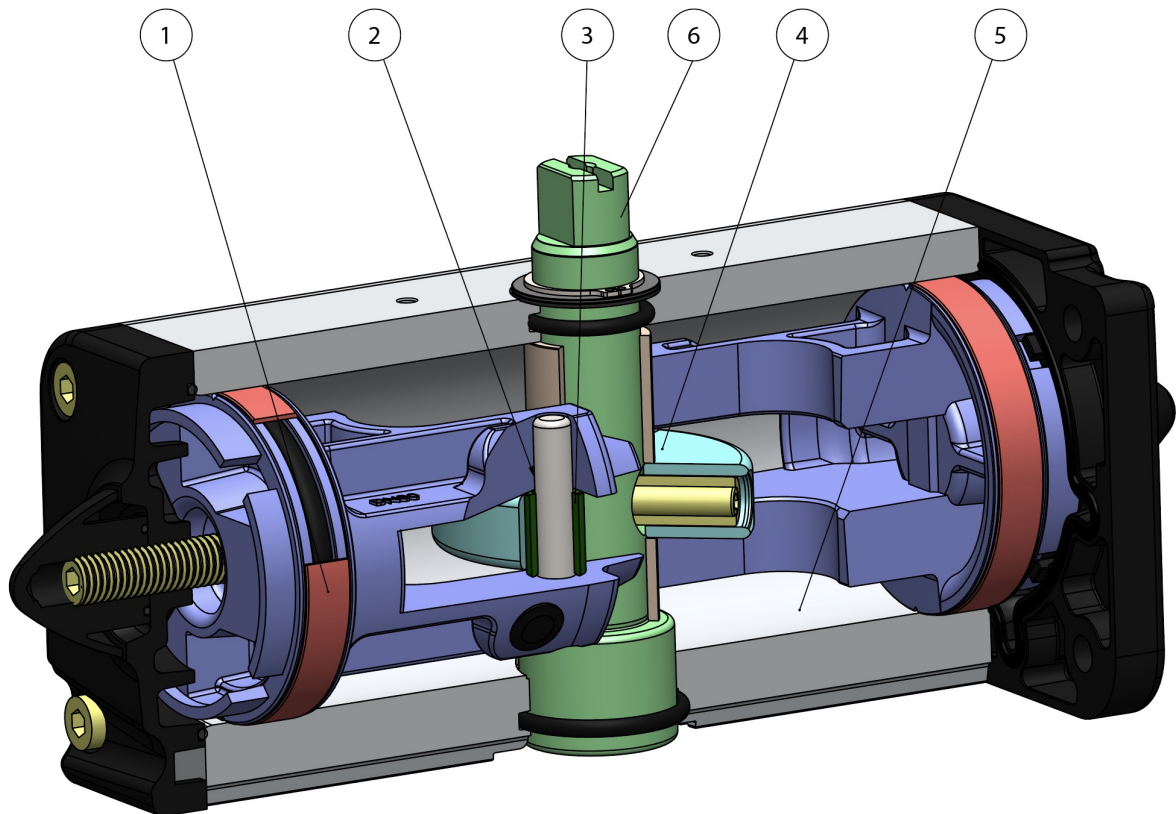

1. Energized and self-lubricated strips

Less friction between piston and cylinder
 It prevents the bonding of the seal to the cylinder even after long periods of inactivity

2. Slots, bushes and pins made by steel with hardness higher than 50 HRC

Higher resistance to the forces inside the actuator

3. Rolling friction between piston and slot

Less friction

4. Scotch yoke with rolling friction (transforming rotary motion into linear motion using piston and shaft without teeth/gears)

Reduced friction between piston and shaft with consequently less wear on the relevant parts
 Empowered Breakaway Torque (BTO & BTC)
 Smaller volume/size than rack and pinion actuators (with the same torque) therefore less space required for installation
 Less weight than the rack and pinion (-30% kg / Nm), with consequent savings on the construction sizing of the plant/equipment
 Lower air consumption compared to the rack and pinion actuators (-40% air cm³/Nm for Double Acting and -20% air cm³/Nm for Spring Return) therefore less load on the compressor or the possibility of using a smaller compressor's size.

5. Rolled cylinder

Less wear of the energized ties thanks to the low roughness of the surface

6. Stainless Steel shaft

Higher corrosion resistance

From sizes bigger than DAN15, NAMUR interface for solenoid valve is already integrated

No need for extra plate.

100% in-house manufacturing process technology

Maximum control and accuracy in all the stages of the manufacturing process

ATEX Certificate

Installation is allowed in a potential explosive environment

Up to SIL 3 Certified

Guarantee of the high level of functional safety.

features

TECHNICAL FEATURES

Torque from 720 Nm to 1920 Nm.

Mounting flange according to EN ISO 5211

F03 - F05 - F07 - F10 - F12 - F16.

In compliance with EN 15714-3.

Rotation angle 92° (-1° +91°)

Torque: directly proportional to the air supply (see table pneumatic actuator DA).

The code numbers after the DA letters, always correspond to the breakaway torque in Nm by 5,6 bar air supply.

Actuator with epoxy painting

ATEX version in conformity with directive 2014/34/EU. Please add YX at the end of the code for ATEX version.

WORKING CONDITION

Temperature: from -20°C to +80°C.

Air supply: 5,6 bar; maximum 8,4 bar.

Actuating media: filtered dry compressed air, not necessarily lubricated. In case of lubricated air, either non detergent oil, NBR compatible oil, must be used.

dimensions

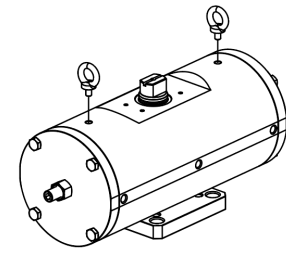
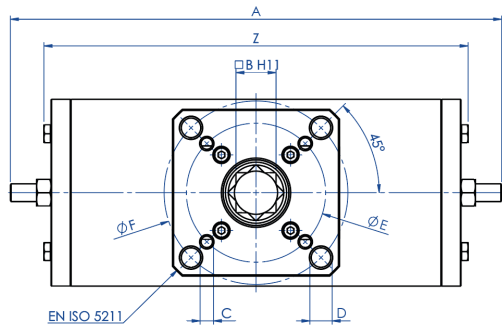

I punti di sollevamento sono progettati per il solo attuatore

Per il sollevamento utilizzare due golfari M10

For the lifting use n° 2 eyebolts M10

Lifting point are designed for actuator only

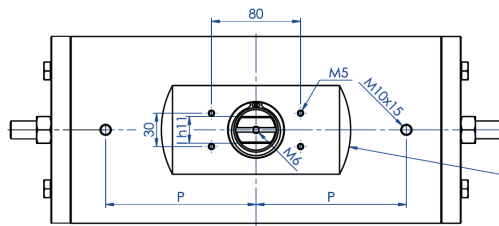
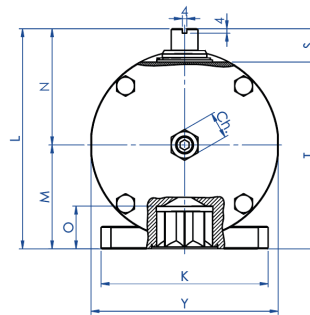
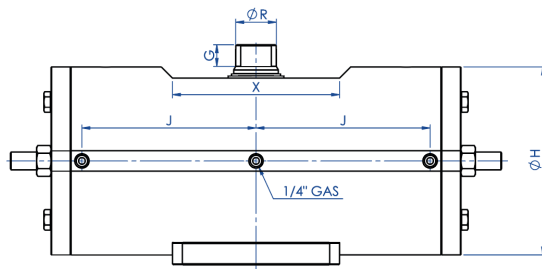

*Interfaccia per accessori
 EN 15714-3 (VDI/VDE 3845)*

*Accessories interface
 EN 15714-3 (VDI/VDE 3845)*

DATA SHEET

Code	DAC0720416S	DAC0960416S	DAC1440424S	DAC1440416S	DAC1920416S
Spare seals	KGXI0023	KGXI0024	KGXI0025	KGXI0025	KGXI0026
Size	DAC0720 F10/F12	DAC0960 F12/F16	DAC1440 F12	DAC1440 F14	DAC1920 F12/F16
A	401,5	441	524,8	524,8	562
B	27	36	36	36	46
C x depth	M10x11,5	M12x20	M12x18	M16x18	M12x23
D x depth	M12x11,5	M20x20	-	-	M20x23
ØE	102	125	125	140	125
ØF	125	165	-	-	165
G	19,5	19,5	19,5	19,5	18,5
ØH	156	169	188	188	211
I	22	24	27	27	32
J	138,5	156,3	179,5	179,5	192
K	115	150	130	130	150
L	178	198	216	216	237,7
M	78,5	93,5	101,5	101,5	114,7
N	99,5	104,5	114,5	114,5	123
O	29,5	38,5	38,5	38,5	48,5
P	116	135	160	160	160
ØR	31,8	36,5	41	41	46
S	30	30	30	30	30
T	148	168	186	186	207,7
X	150	150	150	150	150
Y	155	168	187	187	209
Z	345,8	381	433,8	433,8	469
Ch	24	24	30	30	30
Weight (Kg)	30	40	50,5	50,5	73
Air (dm ³ /cycle) (l/cycle)	3,50	4,9	7,60	7,60	10,2

materials

A105 FROM BAR DOUBLE ACTING AND SPRING RETURN PNEUMATIC ACTUATOR COMPONENTS

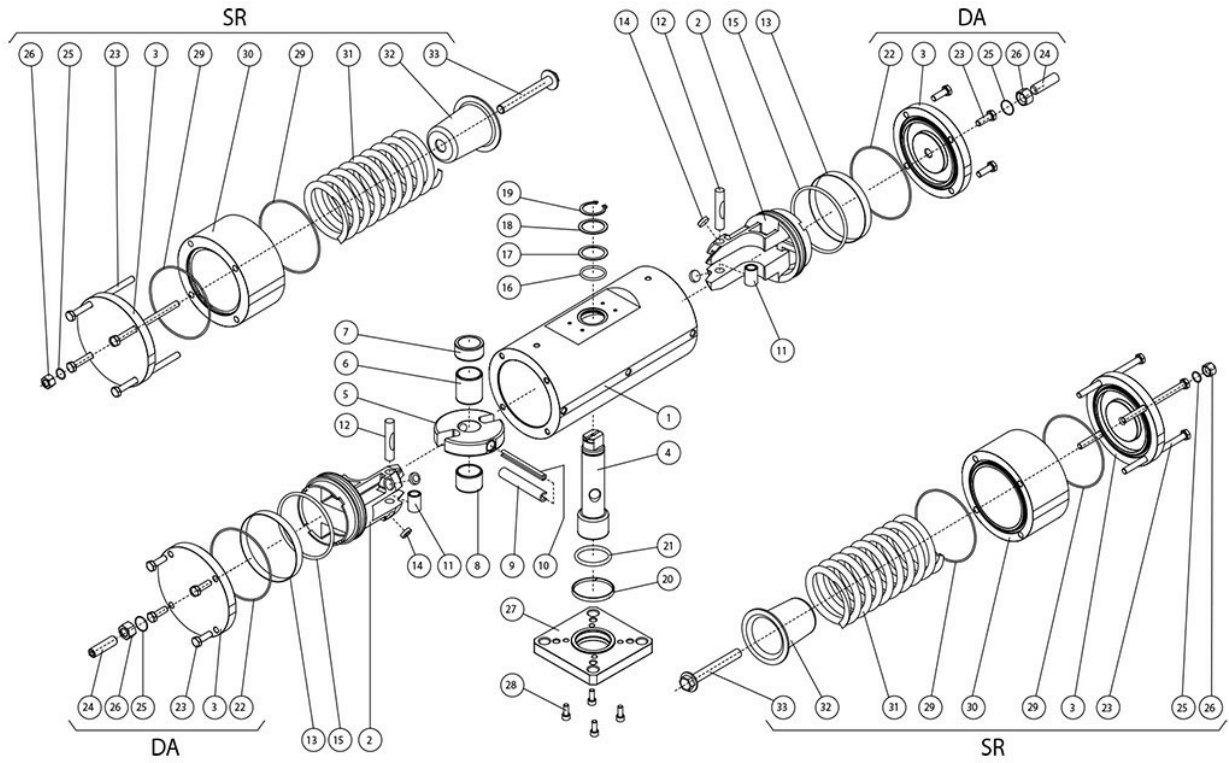

**A105 FROM BAR DOUBLE ACTING AND SPRING RETURN PNEUMATIC ACTUATOR
COMPONENTS**

Pos	Denomination	Q.ty	Material
1	Cylinder	1	Steel alloy
2	Piston	2	Aluminium alloy
3	Cap	2	Steel alloy
4	Shaft	1	Stainless steel
5	Scotch yoke	1	Steel alloy
6	Bearing shaft	1	Acetalic resin
7	Upper shaft support	1	Acetalic resin
8	Bearing shaft	1	Acetalic resin
9	Ext.elastic pin	1	Steel alloy
10	Int.elastic pin	1	Steel alloy
11	Steel bush	2	Steel alloy
12	Rotative sleeve	2	Steel alloy
13*	Dynamic seal	2	Polyurethane
14*	Support disk	4	P.T.F.E. carbo-graphite filled
15*	O-ring	2	Nitrilic rubber
16	O-ring	1	FKM
17	Thrust bearing	1	Acetalic resin
18	Washer	1	Stainless steel
19	Seeger	1	Stainless steel
20	Lower shaft support	1	P.T.F.E. carbo-graphite filled
21	O-ring	1	FKM
22*	GD O-ring	2	Nitrilic rubber
23	Screws	8	Stainless steel
24	Grub screws	2	Stainless steel
25	O-ring	2	Nitrilic rubber
26	Adjusting nut	2	Stainless steel
27	Fixing flange	1	Steel alloy
28	Screws	4	Stainless steel
29*	GS O-ring	4	Nitrilic rubber
30	Cylinder spacer	2	Steel alloy
31	Spring	2	Steel alloy
32	Spring cap	2	Aluminium alloy
33	Spring loading screw	2	Stainless steel
* Components of spare part kit			

specifications

WORKING PLANE PNEUMATIC ACTUATOR "DA" TYPE

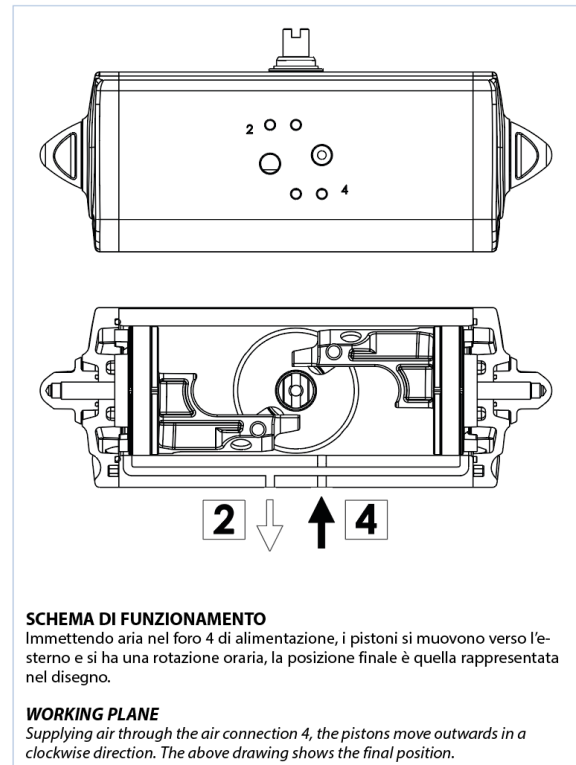
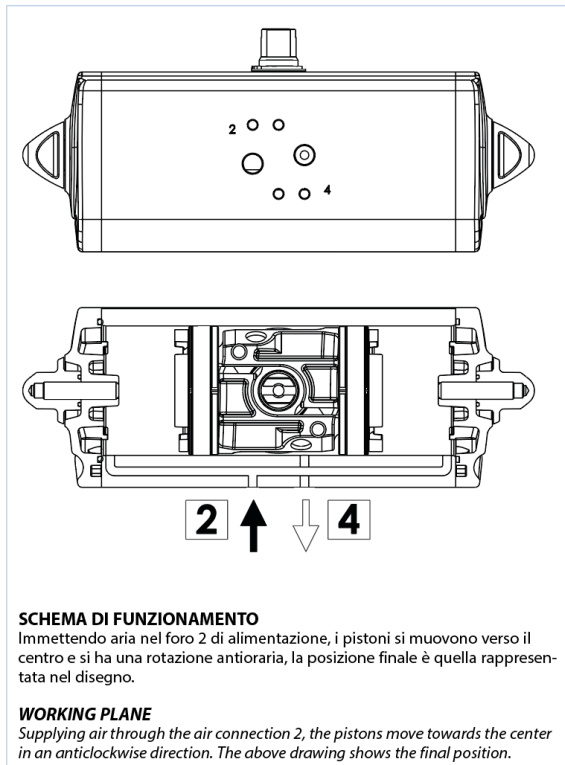

ATTUATORE REGOLABILE-ISTRUZIONI PER L'UTILIZZO ACTUATOR WITH STROKE ADJUSTMENT-INSTRUCTIONS

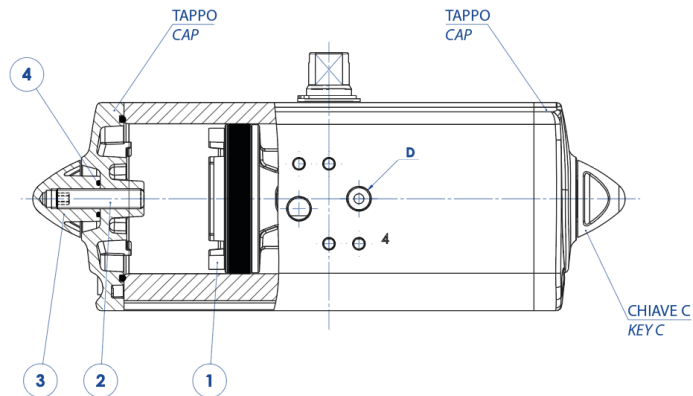

- A)** Immettere aria nel foro "D" in modo che i pistoni (part. n°1) si vengano a trovare in posizione di finecorsa verso i tappi.
B) Togliere il controdado (part. n°3) agendo sulla chiave C.
C) Togliere l'aria di alimentazione.
D) Con una chiave a brugola agire sulle viti (part. n°2) ed effettuare la limitazione di corsa desiderata.
N.B. La corsa può essere limitata per un massimo di 10° da 80° a 90°. Altre regolazioni disponibili a richiesta.
E) Mettere aria nel foro "D", verificare che entrambe le viti (part. n°2) siano a battuta contro i pistoni.
F) Mettere il controdado (part. n°3) munito di O-ring (part. n°4) per la tenuta tra dado e tappo.

- A)** Supply air through the air connection D so that the pistons (Part. 1) move to the end-stroke position, towards the caps.
B) Remove the counter nut (part. 3) acting on the C key.
C) Shut off the air supply.
D) Adjust the end stroke as desired, acting on the screws (part 2) with an hexagonal key.
Note: maximum adjusting stroke 10°, ranging from 80° to 90°. Other regulations on request.
E) Supply air through the air connection D and check that both screws stop the pistons.
F) Screw the counter-nut (part 3) and its o-ring (part 4) to keep nut and cap tight.

documents

Certificati

ATEX - Pneumatic Actuators
SIL EN 61508 - Actuators: SR, SRN, DA, DAN
Type Approval Certificate for Marine and machinery systems and equipment

Istruzioni

ISTRUZIONI ATEX UITGOG01ATX
ISTRUZIONI USO 8_0842

Manuali

MANUALE UMA800081B