

GS (spring return) pneumatic actuator 316 continuous stainless steel bar



Macro Pneumatic actuators

Category Inox 316 from solid bar actuators

Nominal torque of the actuator: from 360 Nm to 1920 Nm

benefits

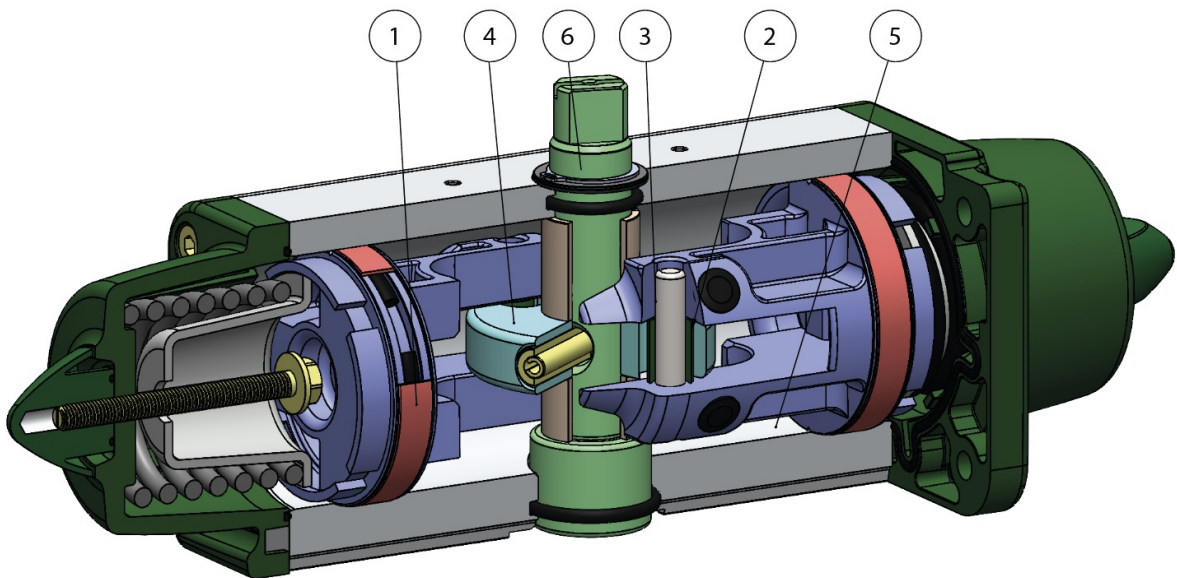

1. Energized and self-lubricated strips

Less friction between piston and cylinder
It prevents the bonding of the seal to the cylinder even after long periods of inactivity

2. Slots, bushes and pins made by steel with hardness higher than 50 HRC

Higher resistance to the forces inside the actuator

3. Rolling friction between piston and slot

Less friction

4. Scotch yoke with rolling friction (transforming rotary motion into linear motion using piston and shaft without teeth/gears)

Reduced friction between piston and shaft with consequently less wear on the relevant parts
Empowered Breakaway Torque (BTO & BTC)
Smaller volume/size than rack and pinion actuators (with the same torque) therefore less space required for installation
Less weight than the rack and pinion (-30% kg / Nm), with consequent savings on the construction sizing of the plant/equipment
Lower air consumption compared to the rack and pinion actuators (-40% air cm³/Nm for Double Acting and -20% air cm³/Nm for Spring Return) therefore less load on the compressor or the possibility of using a smaller compressor's size.

5. Rolled cylinder

Less wear of the energized ties thanks to the low roughness of the surface

6. Stainless steel shaft

Higher corrosion resistance

From sizes bigger than GD15, NAMUR interface for solenoid valve is already integrated

No need for extra plate.

100% in- house manufacturing process technology

Maximum control and accuracy in all the stages of the manufacturing process

ATEX Certificate

Installation is allowed in a potential explosive environment

Up to SIL 3 Certified

Guarantee of the high level of functional safety.

features

TECHNICAL FEATURES

Torque from 360 Nm to 960 Nm

Mounting flange according to EN ISO 5211; F10 - F12 - F14 - F16

In compliance with EN 15714-3

Rotation angle: 92° (-1°, +91°)

Torque: the return torque depends on spring action only notwithstanding the air supply

The spring is provided in four different sizes; see table - general catalogue pneumatic actuator GS br>The actuator automatic closing takes place in clockwise direction by means of its springs

In the code of standard version GS actuators, it is indicated the size of the springs (6=5,6 bar) followed by the breakaway torque in Nm at 5,6 bar air supply.

ATEX version in conformity with directive 2014/34/EU

WORKING CONDITION

Temperature: from -20°C to +80°C

Air supply: 5,6 bar; maximum 8,4 bar

Actuating media: filtered dry compressed air, not necessarily lubricated. In case of lubricated air, either non detergent oil, NBR compatible oil, must be used.

dimensions

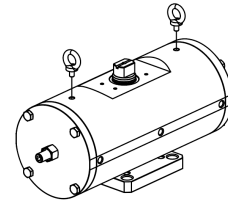
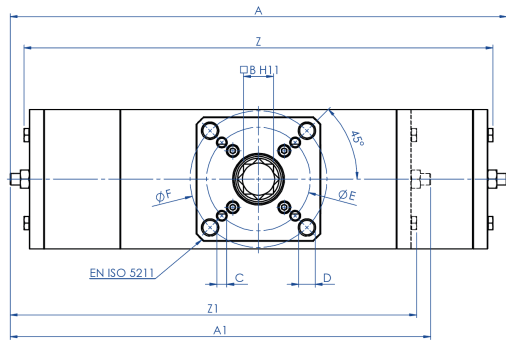

I punti di sollevamento sono progettati per il solo attuatore
Per il sollevamento utilizzare due golfari M10
For the lifting use n° 2 eyebolts M10
Lifting point are designed for actuator only

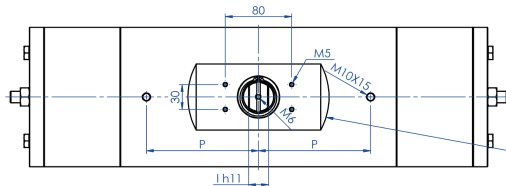
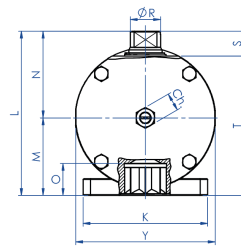
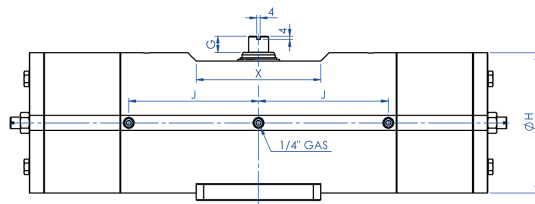

Interfaccia per accessori
 EN 15714-3 (VDI/VDE 3845)
Accessories interface
 EN 15714-3 (VDI/VDE 3845)

DATA SHEET

Spare seals	KGSS223	KGSS224	KGSS225	KGSS225	KGSS226
Size	GS0360 F10/F12	GS0480 F12/F16	GS0720 F12	GS0720 F14	GS0960 F12/F16
A	565,5	598	736,8	736,8	769,6
A1 (2,8 Bar)	483,5	506	630,8	630,8	645
B	27	36	36	36	46
C x depth	M10x11,5	M12x20	M12x18	M16x18	M12x23
D x depth	M12x11,5	M20x20	-	-	M20x23
ØE	102	125	125	140	125
ØF	125	165	-	-	165
G	19,5	19,5	19,5	19,5	18,5
ØH	156	169	188	188	211
I	22	24	27	27	32
J	138,5	156,3	179,5	179,5	192
K	115	150	130	130	150
L	178	198	216	216	237,7
M	78,5	93,5	101,5	101,5	114,7
N	99,5	104,5	114,5	114,5	123
O	29,5	38,5	38,5	38,5	48,5
P	116	135	160	160	160
Q	-	-	-	-	-
Q2	-	-	-	-	-
ØR	31,8	36,5	41	41	46
S	30	30	30	30	30
S2	-	-	-	-	-
T	148	168	186	186	207,7
T2	-	-	-	-	-
X	150	150	150	150	150
Y	155	168	187	187	209
Z	525,8	565	685	685	718,4
Z1 (2,8 Bar)	435,8	473	559,4	559,4	593,8
Ch	22	22	24	24	24
Ch1 (2,8 Bar)	24	24	30	30	30
Weight (Kg)	45,5	60	82,5	82,5	112
Weight (2,8 Bar) (Kg)	37,5	51	77	77	96
Air (dm ³ /cycle) (l/cycle)	2	2,7	4,3	4,3	5,6

316 FROM BAR DOUBLE ACTING AND SPRING RETURN PNEUMATIC ACTUATOR COMPONENTS

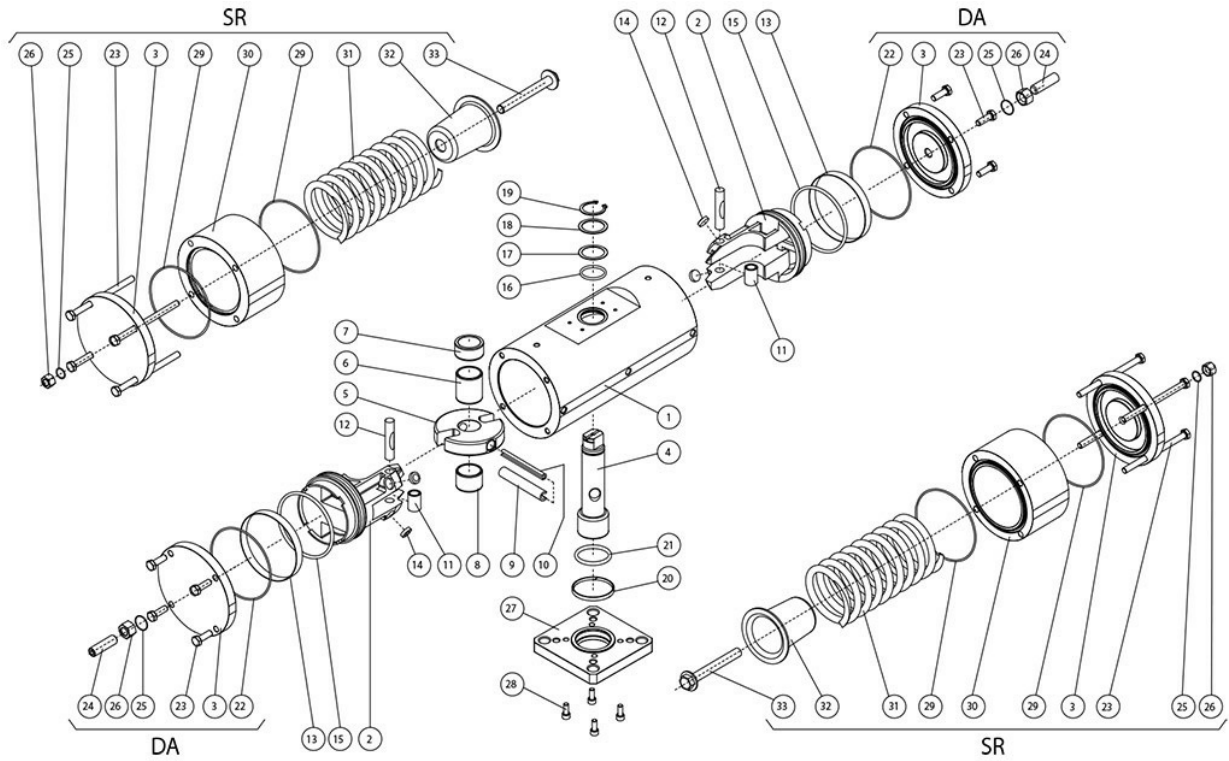

316 FROM BAR DOUBLE ACTING AND SPRING RETURN PNEUMATIC ACTUATOR COMPONENTS

Pos	Denomination	Q.ty	Material
1	Cylinder	1	Stainless steel
2	Piston	2	Aluminium alloy
3	Cap	2	Stainless steel
4	Shaft	1	Stainless steel
5	Scotch yoke	1	Steel alloy
6	Bearing shaft	1	Acetalic resin
7	Upper shaft support	1	Acetalic resin
8	Bearing shaft	1	Acetalic resin
9	Ext.elastic pin	1	Steel alloy
10	Int.elastic pin	1	Steel alloy
11	Steel bush	2	Steel alloy
12	Rotative sleeve	2	Steel alloy
13*	Dynamic seal	2	Plyurethane
14*	Support disk	4	P.T.F.E. carbo-graphite filled
15*	O-ring	2	Nitrilic rubber
16	O-ring	1	FKM
17	Thrust bearing	1	Acetalic resin
18	Washer	1	Stainless steel
19	Seeger	1	Stainless steel
20	Lower shaft support	1	P.T.F.E. carbo-graphite filled
21	O-ring	1	FKM
22*	GD O-ring	2	Nitrilic rubber
23	Screws	8	Stainless steel
24	Grub screws	2	Stainless steel
25	O-ring	2	Nitrilic rubber
26	Adjusting nut	2	Stainless steel
27	Fixing flange	1	Stainless steel
28	Screws	4	Stainless steel
29*	GS O-ring	4	Nitrilic rubber
30	Cylinder spacer	2	Stainless steel
31	Spring	2	Steel alloy
32	Spring cap	2	Aluminium alloy
33	Spring loading screw	2	Stainless steel

* Components of spare part kit

GS PNEUMATIC ACTUATOR OPERATING DIAGRAM

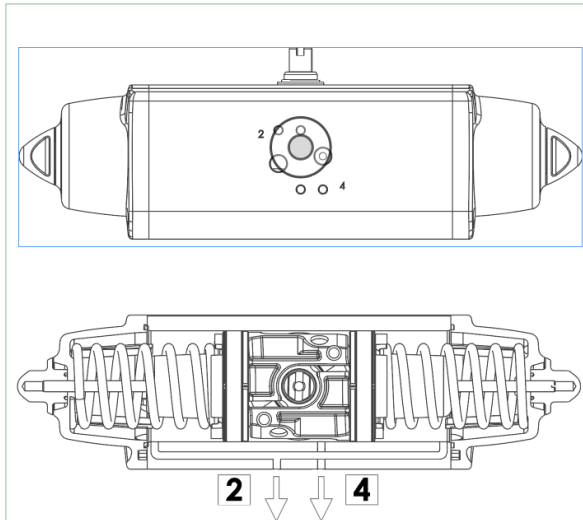

SCHEMA DI FUNZIONAMENTO

Senza pressione di alimentazione, nella versione semplice effetto, l'attuatore torna automaticamente in posizione di riposo compiendo una rotazione oraria e la posizione finale è quella rappresentata nel disegno. Sul foro 2 è consigliato montare un filtrino onde evitare che polvere o particelle solide possano entrare nella camera del cilindro senza tuttavia impedire il passaggio dell'aria.

WORKING PLANE

Without air supply, the spring return actuator returns to its resting position, rotating in a clockwise direction. The drawing shows its final position. We assembling a small filter on the air connection 2 to prevent dust and particles into the cylinder chamber without, however, preventing the passage of air.

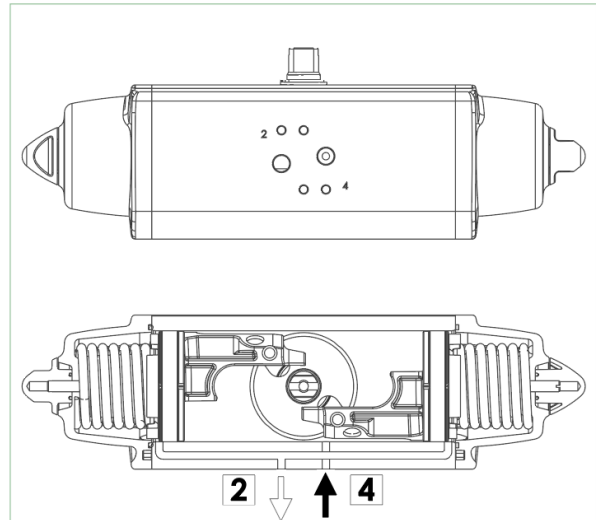

SCHEMA DI FUNZIONAMENTO

Immettendo aria nel foro 4 di alimentazione, i pistoni si muovono verso l'esterno comprimendo le molle, si ha una rotazione antioraria e la posizione finale è quella rappresentata nel disegno.

WORKING PLANE

Supplying air through the air connection 4, the pistons move outwards pressing the spring. An anticlockwise rotation takes place and the final position is shown above.

ATTUATORE REGOLABILE-ISTRUZIONI PER L' UTILIZZO ACTUATOR WITH STROKE ADJUSTMENT-INSTRUCTIONS

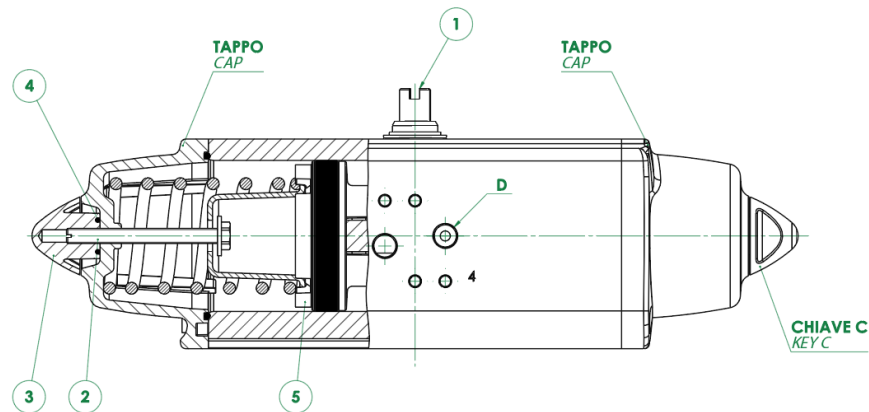

- A) Verificare che le molle siano in posizione di riposo osservando la chiave dell'albero (part. n°1) come da disegno e controllando che nel foro "D" non ci sia pressione.
- B) Togliere i controdadi (part. n°3) agendo sulla chiave C.
- C) Con un cacciavite avvitare le viti (part. n°2) in senso orario ed effettuare la limitazione di corsa desiderata.
- N.B. La corsa può essere limitata per un massimo di 10° da 80° a 90°
- D) Immettere aria nel foro "D" e verificare che entrambe le viti (part. n°2) siano a battuta contro i pistoni (part. n°5).
- E) Bloccare i controdadi (part. n°3) muniti di O-ring (part. n°4) per la tenuta tra controdado, tappo e vite.
- N.B. queste spiegazioni sono indicative, per le istruzioni operative, vedere il manuale.

- A) The springs must be at rest position, the shaft (part. 1) must be as shown in the drawing. Air connection D must not be supplied with air.
- B) Remove the counter-nuts (part. 3), acting on C key.
- C) By means of a screwdriver turn screws (part. 2) in a clockwise direction until you obtain the requested end-stroke regulation.
- Note: maximum adjusting stroke 10°, ranging from 80° to 90°.
- D) Supply connection D with air pressure and check that both adjusting screws (part. 2) stop the pistons (part. 5).
- E) Screw the counter-nuts (part. 3) and their O-ring (part. 4) to keep nut and cap tight.
- N.B. these explanations are indicative, for operating instructions, see the manual.

Drawings on the left = valve in open position
 Drawings on the right = valve in closed position

Typical air connection diagram

The pistons of the standard GS actuators are mounted as shown above. Although the spring force is small, the geometry of the mechanism provides more torque at the end of stroke. When the actuator is in the valve open position and the springs are fully compressed, the end stops can be adjusted with precision. Reverse acting spring return actuators are required when the valve needs to open automatically in the case that the pressurized air or power supply is turned off. In reverse acting actuators, the pistons are inserted into the cylinder in the same way as in the Double Acting version and, due to the force of the spring, the actuator opens normally. Caution. The normal torque performance in the reverse acting version, due to its construction, is different from that of the standard version. Caution. To prevent dust or dirt from being sucked into the actuator chamber during spring action, install a filter on port 2. Port 4 is connected to the middle chamber and, when pressurized, the drive shaft rotates anticlockwise to open. In accordance with the international standard ISO 5599-2, the position, location, orientation and shape of the actuator air port connections must be clearly identified and marketed using numbers 2 and 4.

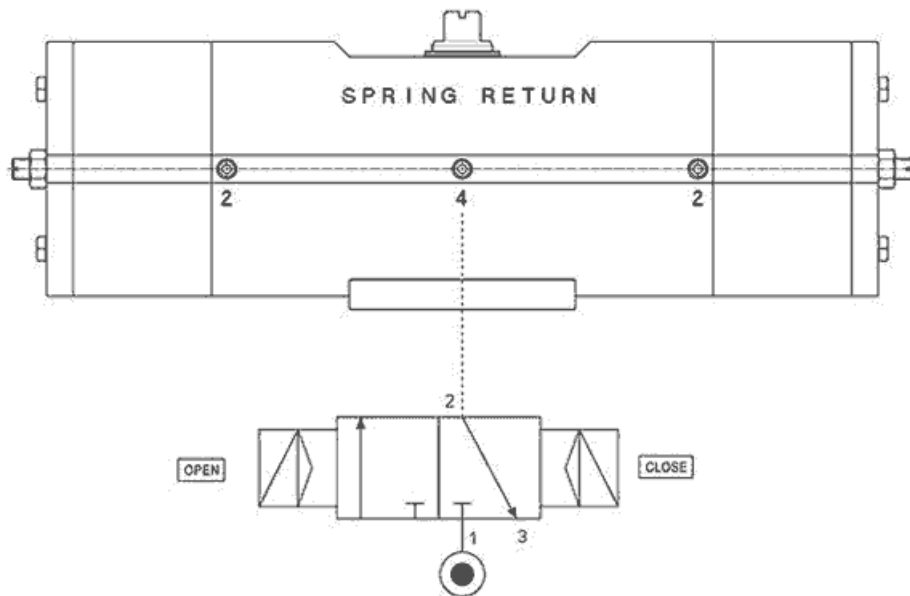

accessories

LIMIT SWITCH BOX



MANUAL OVERRIDE WITH HAND WHEEL



NAMUR SOLENOID VALVES



SOLENOID VALVES



ELECTROPNEUMATIC POSITIONER (INTRINSICALLY SAFE)

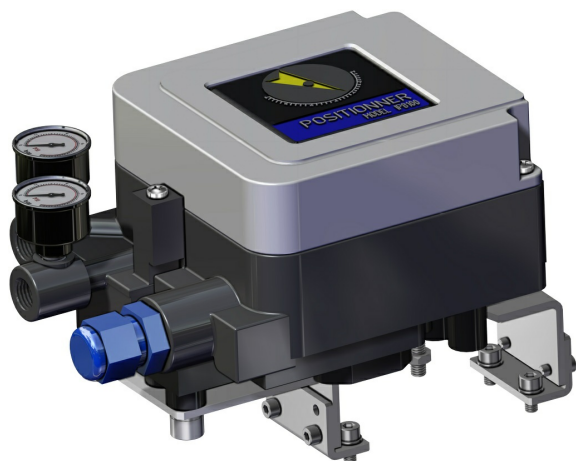

PNEUMATIC POSITIONER



PROXIMITY LIMIT SWITCHES

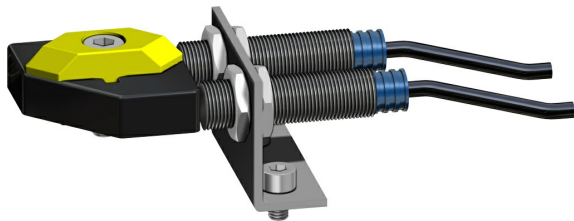

ELECTROMECHANICAL LIMIT SWITCHES

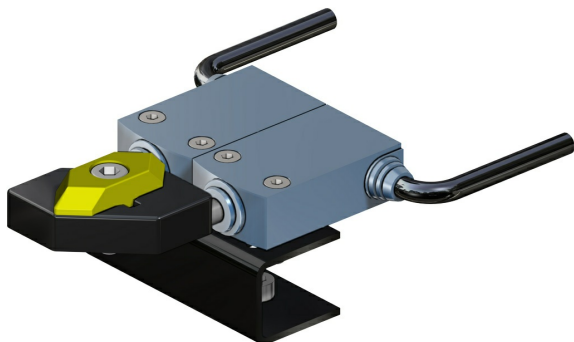

PNEUMATIC LIMIT SWITCHES

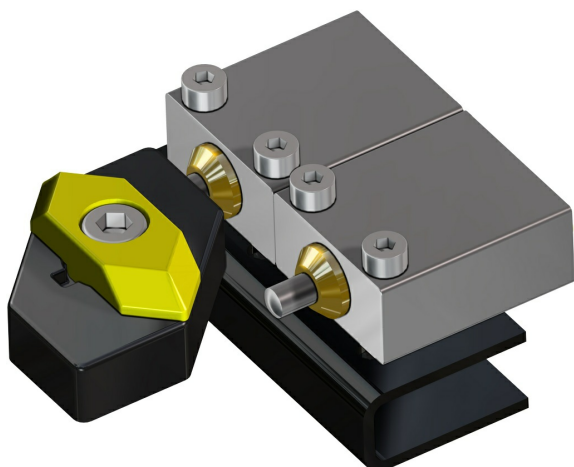

EXPLOSION PROOF LIMIT SWITCHES II2GD ExdIIC

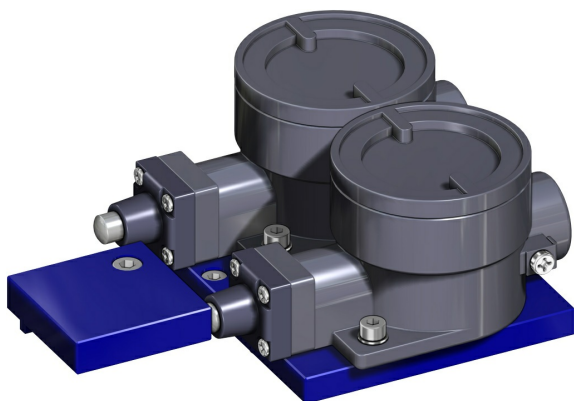

For more information check the ACTUATECH Accessories Catalogue.

documents

Catalogs

ATTUATORI INOX

Certificates

AKNOWLEDGEMENT OF RECEIPT - EC - ATEX

SIL CERTIFICATE GS

Datasheet

GS0480F14INOX

GS0960F12F16INOX

GS1920F16INOX

GS0480F12F16INOX

GS0720F14INOX

GS1920F14INOX

GS0360F10F12INOX

GS0720F12INOX