

GD (double acting) pneumatic actuator CF8M (microcast stainless steel)

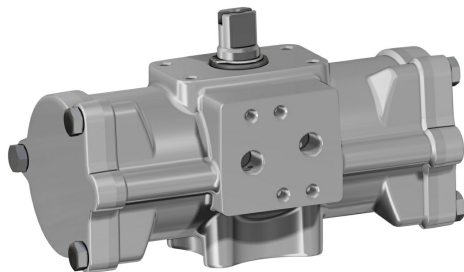

Macro Pneumatic actuators

Category Inox precision casting CF8M actuators

Nominal torque of the actuator: from 15 Nm to 480 Nm

benefits

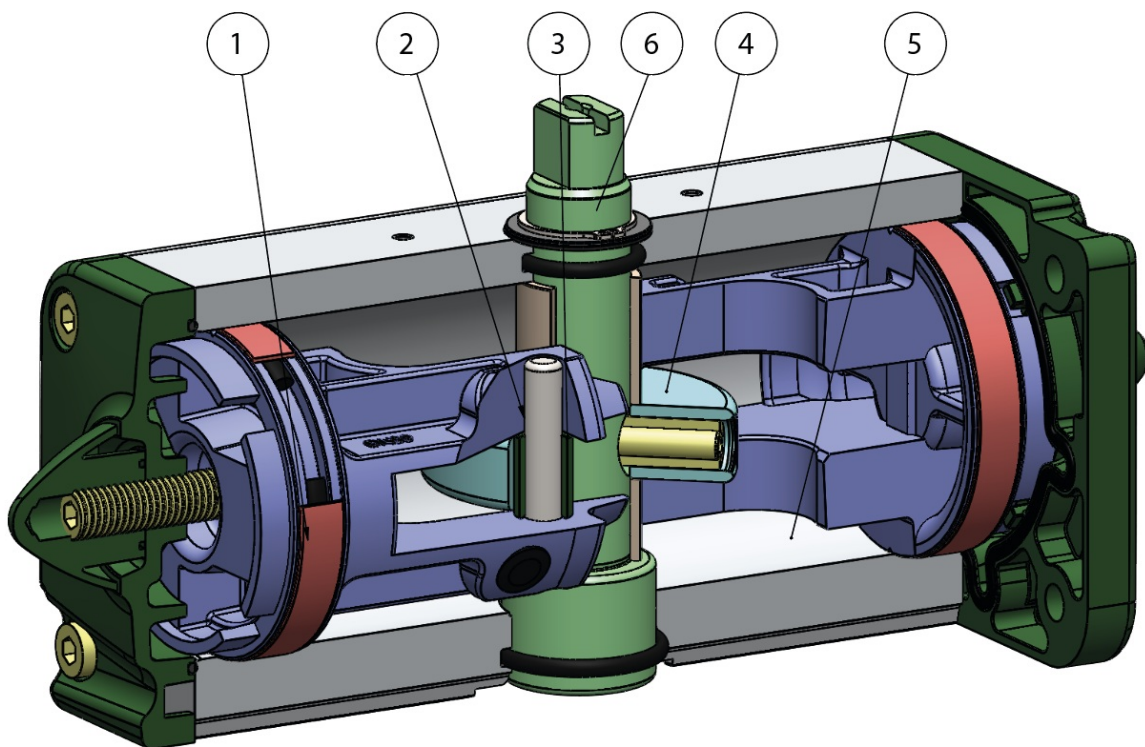

1. Energized and self-lubricated strips

Less friction between piston and cylinder

It prevents the bonding of the seal to the cylinder even after long periods of inactivity

2. Slots, bushes and pins made by steel with hardness higher than 50 HRC

Higher resistance to the forces inside the actuator

3. Rolling friction between piston and slot

Less friction

4. Scotch yoke with rolling friction (transforming rotary motion into linear motion using piston and shaft without teeth/gears)

Reduced friction between piston and shaft with consequently less wear on the relevant parts

Empowered Breakaway Torque (BTO & BTC)

Smaller volume/size than rack and pinion actuators (with the same torque) therefore less space required for installation

Less weight than the rack and pinion (-30% kg / Nm), with consequent savings on the construction sizing of the plant/equipment

Lower air consumption compared to the rack and pinion actuators (-40% air cm³/Nm for Double Acting and -20% air cm³/Nm for Spring Return) therefore less load on the compressor or the possibility of using a smaller compressor's size.

5. Rolled cylinder

Less wear of the energized ties thanks to the low roughness of the surface

6. Stainless steel shaft

Higher corrosion resistance

From sizes bigger than GD15, NAMUR interface for solenoid valve is already integrated

No need for extra plate.

100% in- house manufacturing process technology

Maximum control and accuracy in all the stages of the manufacturing process

ATEX Certificate

Installation is allowed in a potential explosive environment

Up to SIL 3 Certified

Guarantee of the high level of functional safety.

features

TECHNICAL FEATURES

Torque from 15 Nm to 480 Nm

Mounting flange according to ISO 5211; F03 - F05 - F07 - F10

In compliance with EN 15714-3

Rotation angle: 92° (-1°, +91°)

Torque: directly proportional to the air supply (see table - general catalogue pneumatic actuator GD)

In the code of standard version GD actuators, it is indicated the breakaway torque in Nm at 5,6 bar air supply.

Sizes from GD 60 direct connection with NAMUR solenoid valve

Sizes GD15 - GD30 can be provided with NAMUR plate on request

ATEX version in conformity with directive 2014/34/EU

WORKING CONDITION

Temperature: from -20°C to +80°C

Air supply: 5,6 bar; maximum 8,4 bar

Actuating media: filtered dry compressed air, not necessarily lubricated. In case of lubricated air, either non detergent oil, NBR compatible oil, must be used.

dimensions

GD15 ÷ GD30

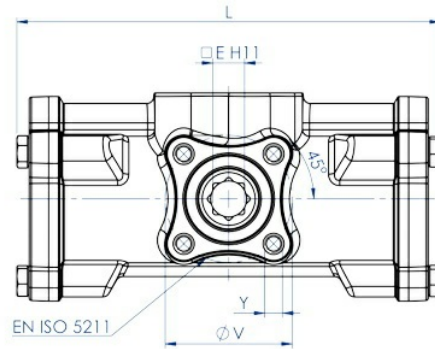

Interfaccia EN 15714-3 (Namur) a richiesta
EN 15714-3 (Namur) interface on request

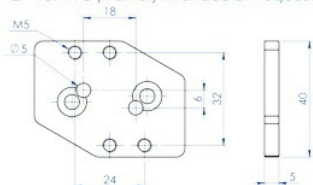

Optional Code KBNI4015

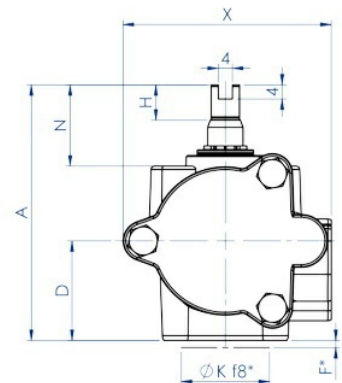
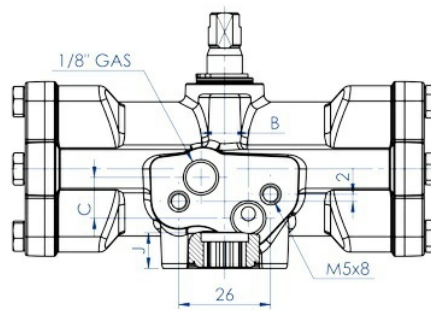

*Anello di centraggio
Centering ring

Interfaccia EN 15714-3 (Namur) a richiesta
EN 15714-3 (Namur) interface on request

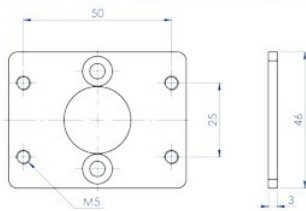

Optional Code KBVI4015

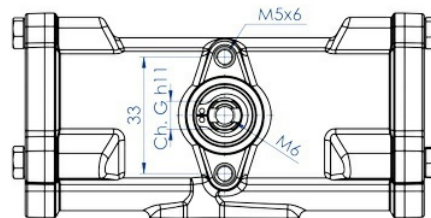

GD60 ÷ GD480

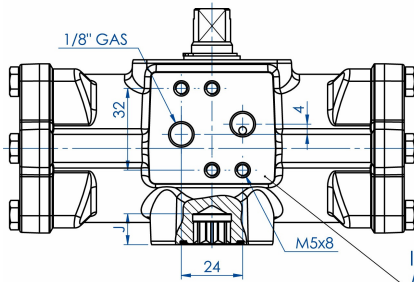
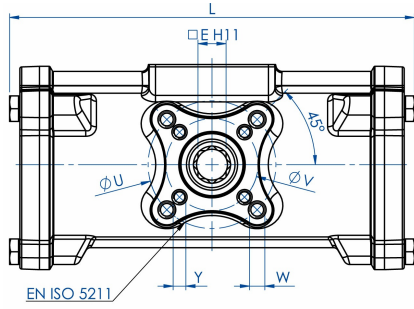

Interfaccia EN 15714-3 (Namur)
EN 15714-3 (Namur) interface

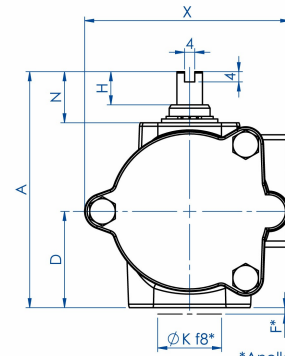

*Anello di centraggio
Centering ring

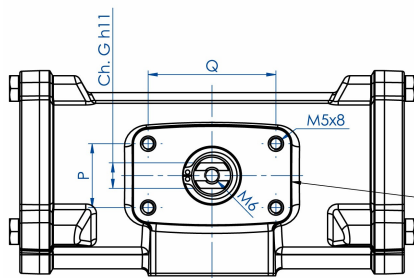

Interfaccia per accessori
EN 15714-3 (VDI/VDE 3845)
Accessories interface
EN 15714-3 (VDI/VDE 3845)

DATA SHEET

Spare seals	KGSS112	KGSS114	KGSS116	KGSS118	KGSS120	KGSS122
Size	GD15 F03	GD30 F03	GD60 F03-F05	GD120 F05-F07	GD240 F05-F07	GD480 F07-F10
L mm.	120	134,6	158,4	192,9	246,8	298,4
A mm.	72,4	80,4	92,5	116,5	136,4	160
B mm.	13,4	11,6	-	-	-	-
C mm.	12	13	-	-	-	-
D mm.	28,2	32,7	37,7	46,2	56,2	68
E mm.	9	9	11	14	17	22
F mm.	2	2	2	3	3	3
Ch, G mm.	8	9	10	12	15	19
H mm.	10	10	13	13	17	19
N mm.	23	23	20	30	30	30
X mm.	59	68	80,3	94,4	117	139,7
J mm.	10,2	10,2	12,2	16,3	19,3	24,3
ØK mm.	25	25	25	35	35	55
Q mm.	50	50	50	80	80	80
P mm.	25	25	25	30	30	30
ØU mm.	-	-	50	70	70	102
ØV mm.	36	36	36	50	50	70
Y x prof. depth mm.	M5x9	M5x9	M5x9	M6x11	M6x11	M8x13
W x prof. depth mm.	-	-	M6x11	M8x15	M8x13	M10x22
air dm ³ /cycle	0,08	0,16	0,30	0,61	1,26	2,46
weight Kg.	0,8	1,2	1,8	3,3	5,6	9,5

CASTING CF8M DOUBLE ACTING PNEUMATIC ACTUATOR COMPONENTS SIZE: GD 15-GD 30

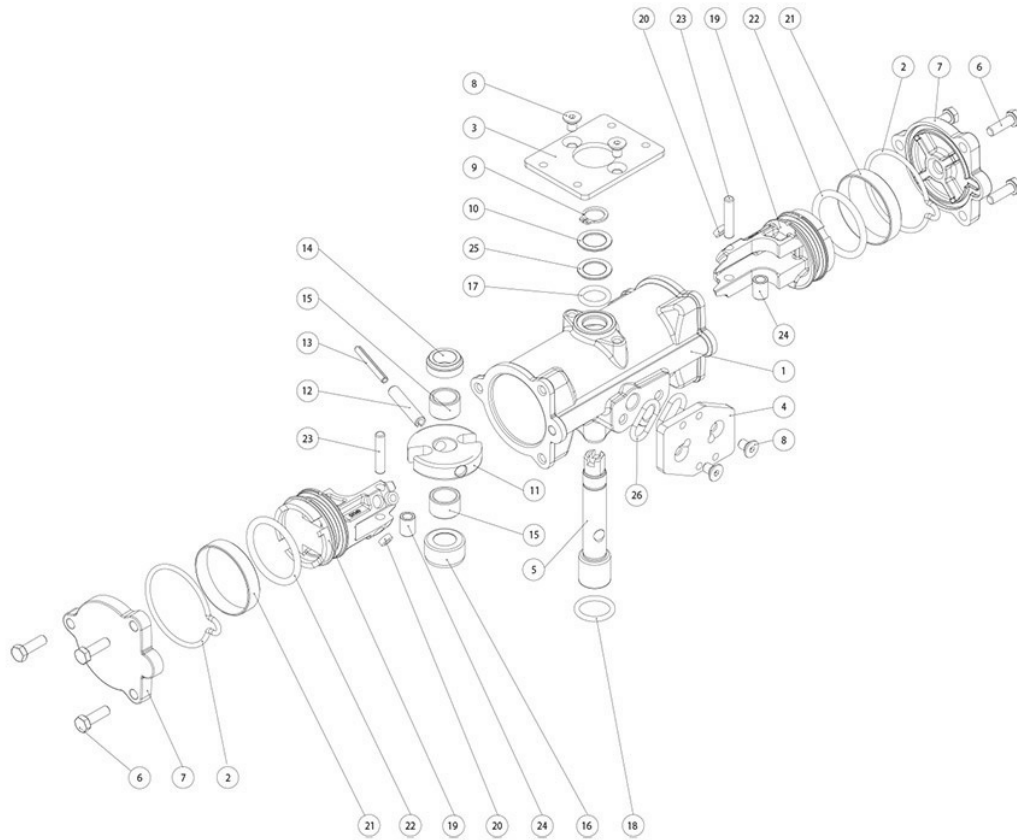

MATERIALS: GD 15 ÷ GD 30			
Pos	Denomination	Q.ty	Material
1	Cylinder	1	Stainless steel CF8M
2*	Cap o-ring	2	Nitrilic rubber
3	Plate	1	Stainless steel
4	NAMUR plate	1	Stainless steel
5	Shaft	1	Stainless steel
6	Screw	6	Stainless steel
7	Cap	2	Stainless steel
8	Screw (optional)	4	Stainless steel
9	Seeger	1	Stainless steel
10	Washer	1	Stainless steel
11	Scotch yoke	1	Steel alloy
12	External elastic pin of the yoke	1	Steel alloy
13	Internal elastic pin of the yoke	1	Steel alloy
14	Upper shaft support	1	Acetalic resins
15	Support bush	2	Acetalic resins
16	Lower shaft support	1	Acetalic resins
17*	O-ring (upper sealing shaft)	1	FKM
18*	O-ring (low sealing shaft)	1	FKM
19	Piston	2	Aluminium alloy
20*	Piston's support	4	P.T.F.E. carbo-graphite filled
21*	Dynamic seal (piston)	2	Polyurethane
22*	Piston o-ring	2	Nitrilic rubber
23	Rotative sleeve	2	Steel alloy
24	Bush	2	Steel alloy
25*	External support ring	1	Acetalic resins
26	O-ring (optional)	2	Nitrilic rubber

* Components of spare part kit

CASTING CF8M DOUBLE ACTING PNEUMATIC ACTUATOR COMPONENTS SIZE: GD60-GD480

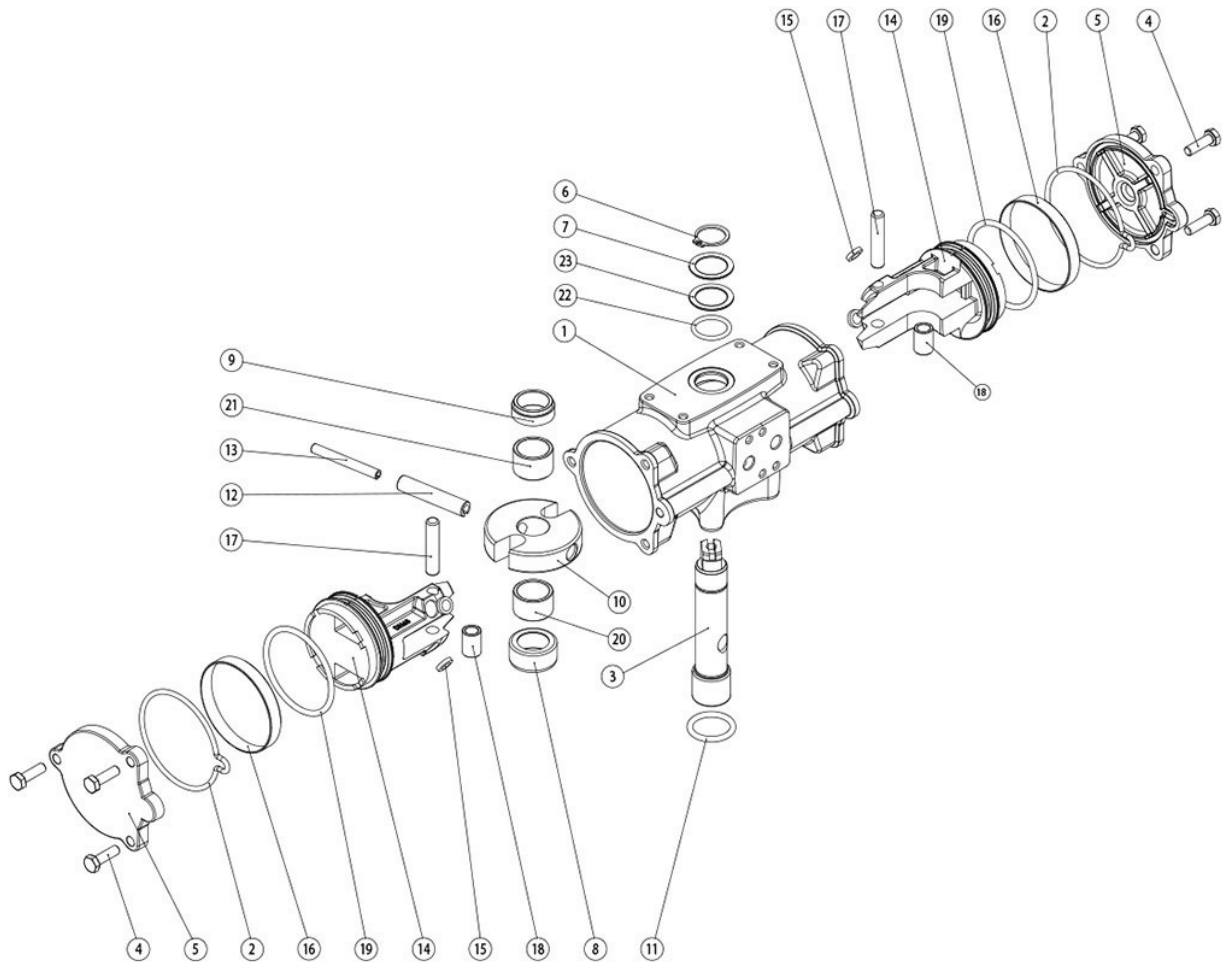

MATERIALS				
Pos	Denomination	Q.ty	Material	
1	Cylinder	1	Stainless steel	
2*	Cap o-ring	2	Nitrilic rubber	
3	Shaft	1	Stainless steel	
4	Screw	6	Stainless steel	
5	Cap	2	Stainless steel	
6	Seeger	1	Stainless steel	
7	Washer	1	Stainless steel	
8	Lower shaft support	1	Acetalic resins	
9	Upper shaft support	1	Acetalic resins	
10	Scotch yoke	1	Steel alloy	
11*	O-ring (low sealing shaft)	1	FKM	
12	External elastic pin of the yoke	1	Steel alloy	
13	Internal elastic pin of yoke	1	Steel alloy	
14	Piston	2	LAluminium alloy	
15*	Piston's support	4	P.T.F.E. carbo-graphite filled	
16*	Dynamic seal (piston)	2	Polyurethane	
17	Rotative sleeve	2	Steel alloy	
18	Bush	2	Steel alloy	
19*	Piston o-ring	2	Nitrilic rubber	
20	Suwer support bush	1	Acetalic resins	
21	Upper support bush	1	Acetalic resins	
22*	O-ring (upper sealing shaft)	1	FKM	
23*	External support ring	1	Acetalic resins	

*Components of spare part kit

GD PNEUMATIC ACTUATOR OPERATING DIAGRAM

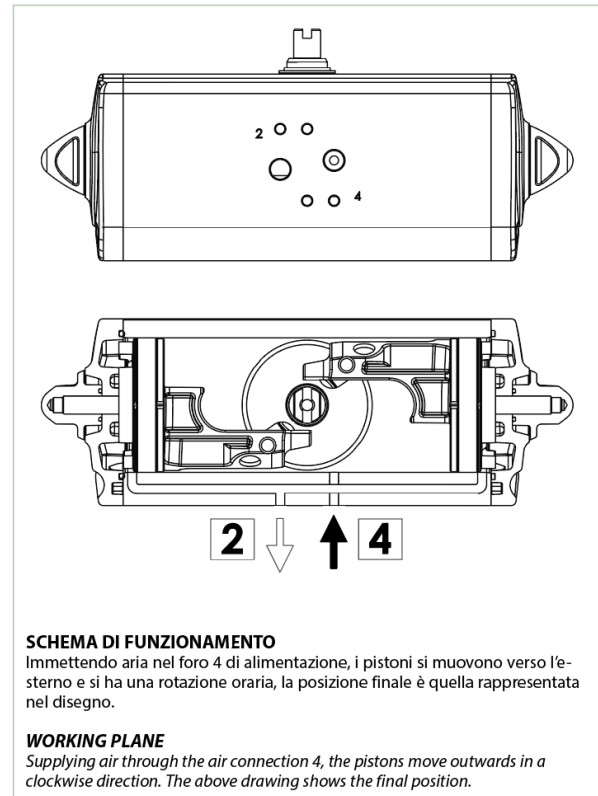
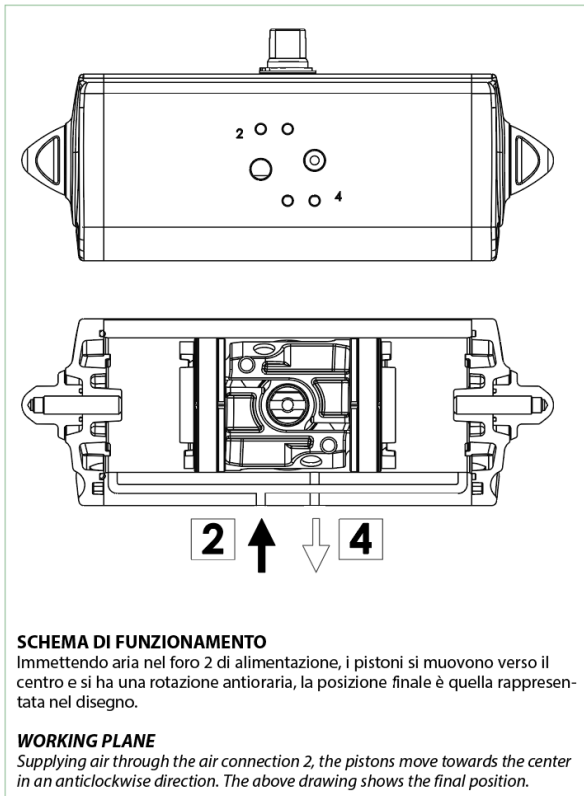

ATTUATORE REGOLABILE-ISTRUZIONI PER L' UTILIZZO ACTUATOR WITH STROKE ADJUSTMENT-INSTRUCTIONS

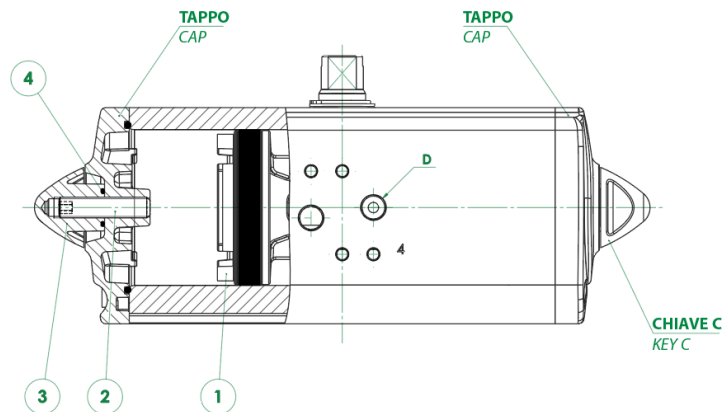

- A) Immettere aria nel foro "D" in modo che i pistoni (part. n°1) si vengano a trovare in posizione di finecorsa verso i tappi.
 - B) Togliere il controdado (part. n°3) agendo sulla chiave C.
 - C) Togliere l'aria di alimentazione.
 - D) Con una chiave a brugola agire sulle viti (part. n°2) ed effettuare la limitazione di corsa desiderata.
 - N.B.** La corsa può essere limitata per un massimo di 10° da 80° a 90°. Altre regolazioni disponibili a richiesta.
 - E) Mettere aria nel foro "D", verificare che entrambe le viti (part. n°2) siano a battuta contro i pistoni.
 - F) Mettere il controdado (part. n°3) munito di O-ring (part. n°4) per la tenuta tra dado e tappo.
- N.B.** queste spiegazioni sono indicative, per le istruzioni operative, vedere il manuale.

- A) Supply air through the air connection D so that the pistons (Part. 1) move to the end-stroke position, towards the caps.
 - B) Remove the counter nut (part. 3) acting on the C key.
 - C) Shut off the air supply.
 - D) Adjust the end stroke as desired, acting on the screws (part 2) with an hexagonal key.
 - Note:** maximum adjusting stroke 10°, ranging from 80° to 90°. Other regulations on request.
 - E) Supply air through the air connection D and check that both screws stop the pistons.
 - F) Screw the counter-nut (part 3) and its o-ring (part 4) to keep nut and cap tight.
- N.B.** these explanations are indicative, for operating instructions, see the manual.

accessories

LIMIT SWITCH BOX

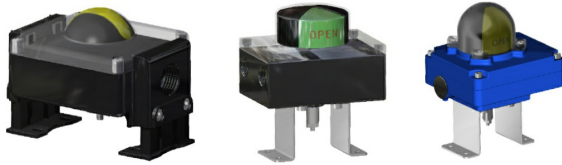

MANUAL OVERRIDE WITH HAND WHEEL



NAMUR SOLENOID VALVES



SOLENOID VALVES



ELECTROPNEUMATIC POSITIONER (INTRINSICALLY SAFE)

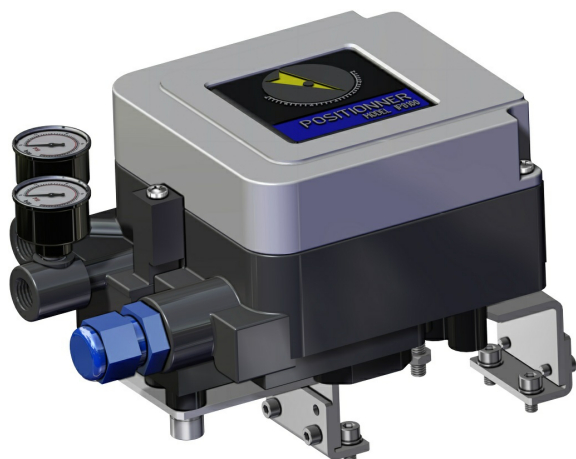

PNEUMATIC POSITIONER



PROXIMITY LIMIT SWITCHES

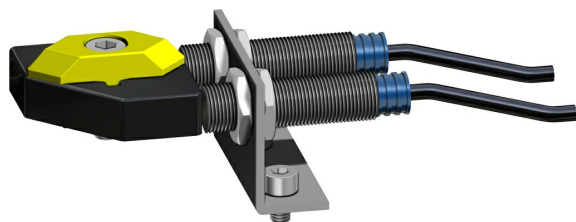

ELECTROMECHANICAL LIMIT SWITCHES

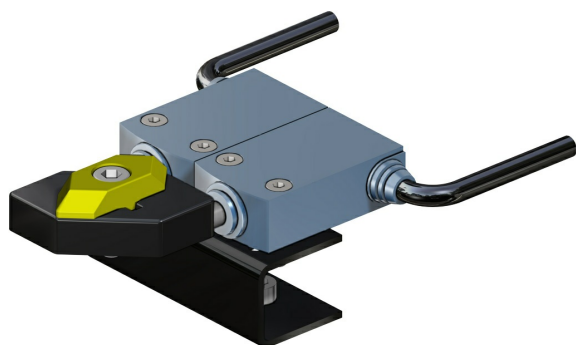

PNEUMATIC LIMIT SWITCHES

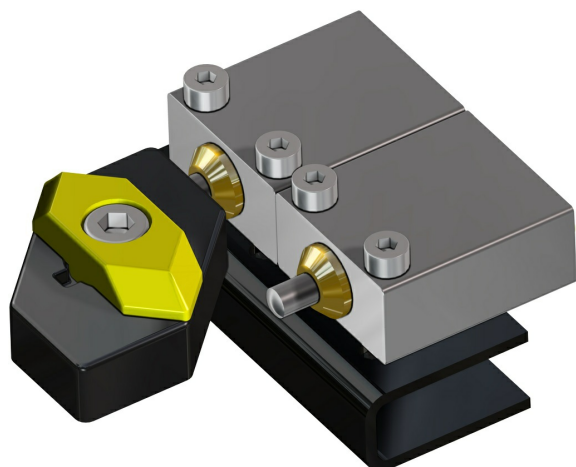

EXPLOSION PROOF LIMIT SWITCHES II2GD ExdIIC

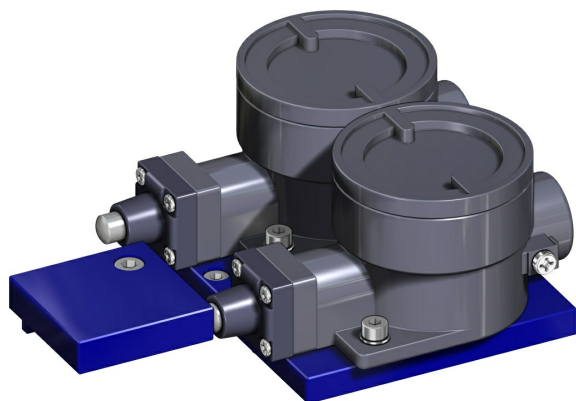

For more information check the ACTUATECH Accessories Catalogue.

documents

Catalogs

ATTUATORI INOX

Certificates

AKNOWLEDGEMENT OF RECEIPT - EC - ATEX

SIL CERTIFICATE GD

Datasheet

GD0120F05F07INOX

GD0030F03INOX

GD0480F07F10INOX

GD0015F03INOX_OPT

GD0060F03F05INOX

GD0240F05F07INOX

GD0015F03INOX

GD0030F03INOX_OPT