

# RK0020VOARS6003Q11G

Pneumatic actuators - RACKON - Rack & Pinion  
 pneumatic actuators N.C. RK20 F03/F05 11  
 Basetta Namur GAS



Drive: N.C.  
 Size: RK20  
 ISO: F03/F05  
 Star Shaft: 11  
 Air Connection: Basetta Namur GAS

**134,00 €** Excl. VAT  
 list price

Article	Weight [kg]
RK0020VOARS6003Q11G	1.50

## GENERAL INFO RACKON - Spring return SR

benefits

**RACK & PINION KINEMATICS**

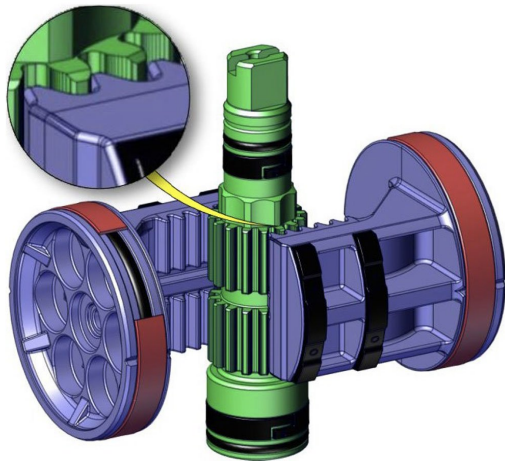

**DOUBLE ADJUSTMENT**

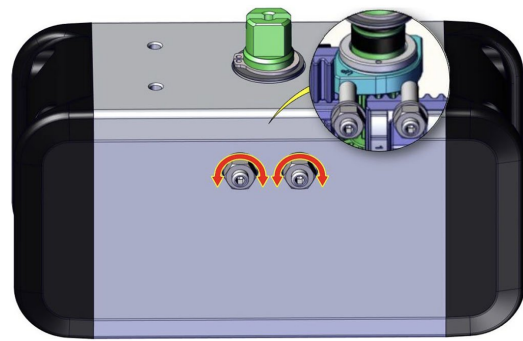

**DA DOUBLE ACTING**

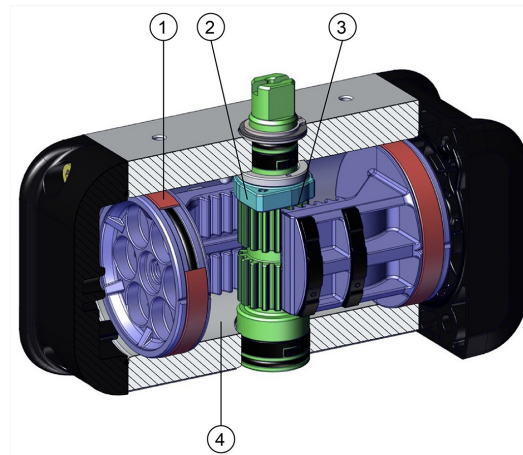

**SR SPRING RETURN**

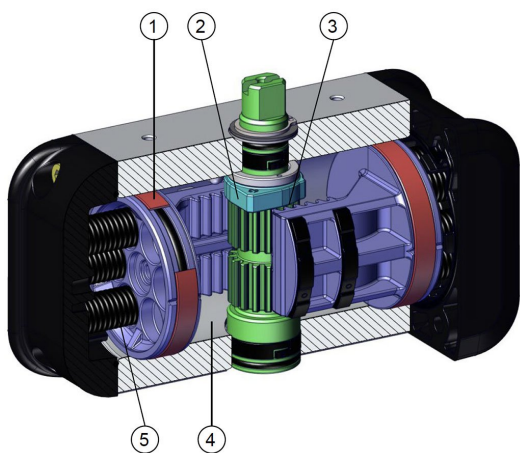

**1. Energized and self-lubricated strips.**

Less friction between piston and cylinder.

It prevents the bonding of the seal to the cylinder even after long periods of inactivity.

**2. Adjustment cam made by steel.**

Possibility to adjust the closing and/or opening with a standard actuator ( $\pm 5^\circ$  for each adjustment).

Simplicity and reliability of adjustment.

**3. Transformation of linear motion into rotary motion using Rack and Pinion kinematics.**

Linear torque (BTO & BTC), suitable for ball valves.

High adjustment precision thanks to the rigidity of the rack and pinion system and the mechanical stop between cam and adjustment grub screw.

Uniform rotation speed.

**4. Rolled cylinder.**

Less wear of the energized ties thanks to the low roughness of the surface (0.15  $\mu\text{m Ra}$ ).

**5. Cartridge spring modular system.**

High configuration flexibility and precision of the torque generated by the springs.

High range of configurations.

**NAMUR interface for solenoid valves can be available on complete range.**

With plate reported from RK10 to RK240. - Integrated for RK 300 and RK480.

**NPT air hole threads available on request.**

With plate reported for all sizes.

**100% in- house manufacturing process technology.**

Maximum control and accuracy in all the stages of the manufacturing process.

**ATEX compliance.**

Installation is allowed in a potential explosive environment.

**Up to SIL 3 Certified.**

Guarantee of the high level of functional safety.

## features

### TECHNICAL FEATURES

- Torque from 15 Nm to 347 Nm.
- Mounting flange according to EN ISO 5211: F03 - F04 - F05 - F07 - F10 - F12.
- In accordance with EN 15714-3.
- In conformity with directive ATEX 2014/34/EU.
- Rotation angle: 100° (-5°, +95°).
- Double adjusting +5° and -5° for each end position (0° and 90°).
- Torque: Depending to the air supply pressure and spring size (see table).

### WORKING CONDITIONS

- Standard temperature range: -20°C +80°C.  
Special versions:
  - high temperature: -20°C +150°C.
  - low temperature: -50°C +60°C.
- Nominal air supply: 6 bar (RS60 standard version); maximum 8 bar.
- Operating medium: filtered compressed air, no lubrication needed according to UNI EN 15714-3:2009.
- In case of lubrication, use non-detergent oil, compatible with the internal seals.

### SPECIAL VERSION ON REQUEST, CODING KEY

CHARACTERISTIC		
Actuator Type	RK	
Size	0010, 0020, 0040, 0060, 0080, 00120, 00160, 0240, 0300, 0480	
Customer	VO	OMAL
Rotation Angle [°]	A	90°
	B*	180°
	C*	120°
	D*	135°
Rotation direction	R	Clockwise rotation
	L	Counter-clockwise rotation
Functioning configuration	S	Spring Return N.C.
	O	Spring Return N.O.
	D	Double Acting
Springs	00	No springs
	20	Springs 2,0 bar
	25	Springs 2,5 bar
	30	Springs 3,0 bar
	35	Springs 3,5 bar
	40	Springs 4,0 bar
	45	Springs 4,5 bar
	50	Springs 5,0 bar
Flange or smaller flange in case of double flange available	55	Springs 5,5 bar
	60	Springs 6,0 bar
	03	F03
	04	F04
	05	F05
	07	F07
Shaft shape	10	F10
	12	F12
Shaft dimension	Q	Star shaft
	D*	Flat head shaft
	09	Shaft dimension 9 mm
	11	Shaft dimension 11 mm
	14	Shaft dimension 14 mm
	17	Shaft dimension 17 mm
Air connection	22	Shaft dimension 22 mm
	27	Shaft dimension 27 mm
	G	Namur plate GAS
	N	Namur plate NPT
Version	0	Gas Thread on the cylinder (no Namur interface)
	1	Namur interface, integrated Gas threads
	-	Standard
	6*	Low temperature
	4*	Low temperature

\* Only on request.

N.B. For special versions contact OMAL.

#### CODING EXAMPLE FOR RACKON

Product Code: [RK0040VOARD0005Q1IG](#)

Product description: RACKON 40 PNEUMATIC ACTUATOR DOUBLE ACTING ISO F05 07 STAR SHAFT 11mm WITH GAS NAMUR PLATE.

Product Code: **RK0300VOARD0007Q22I**

Product description: RACKON 300 PNEUMATIC ACTUATOR DOUBLE ACTING ISO F07 10 STAR SHAFT 22mm NAMUR GAS INTERFACE INTEGRATED ON BODY.

Product Code: **RK0040VOARS6005Q11G**

Product description: RACKON 40 PNEUMATIC ACTUATOR SPRING RETURN 6BAR ISO F05 07 STAR SHAFT 11mm WITH GAS NAMUR PLATE.

Product Code: **RK0300VOARS6007Q22I**

Product description: RACKON 300 PNEUMATIC ACTUATOR SPRING RETURN 6BAR ISO F07 10 STAR SHAFT 22mm NAMUR GAS INTERFACE INTEGRATED ON BODY.

## dimensions

### RK20 ÷ RK240

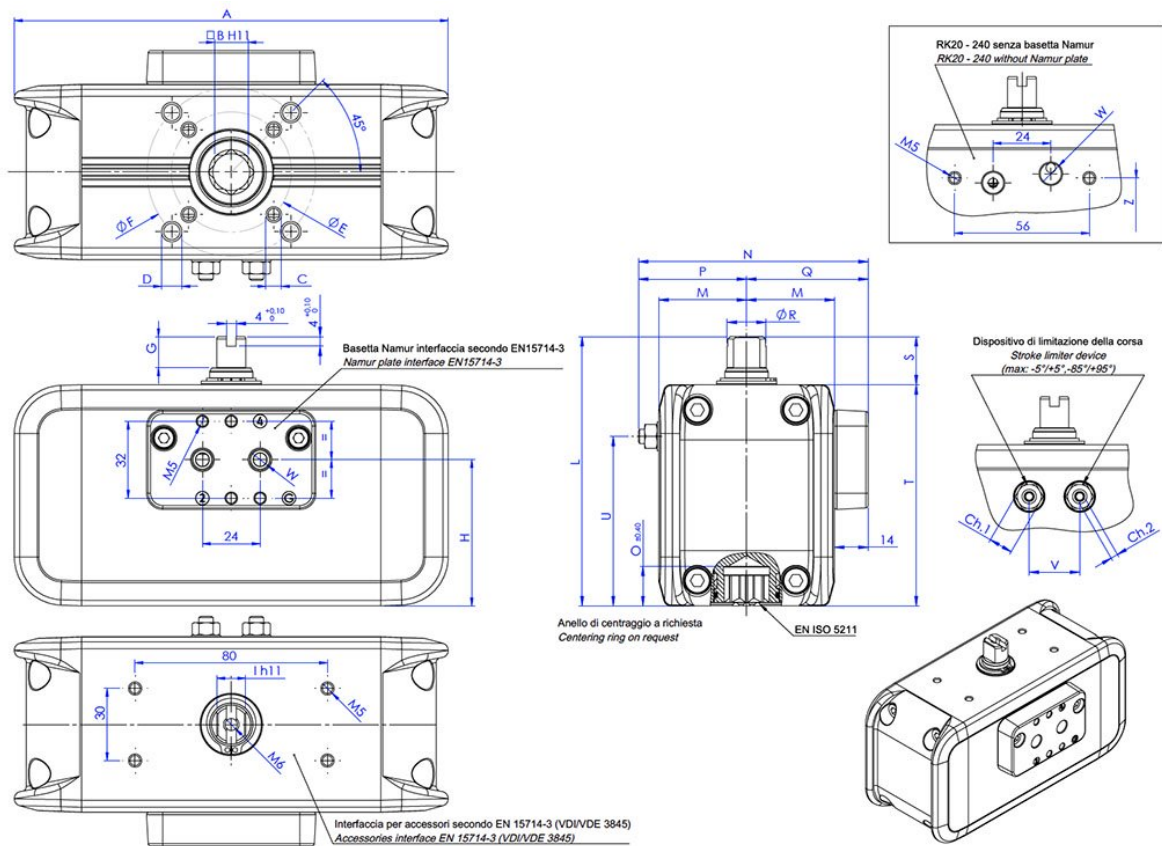

DIMENSIONS [mm]													
Size	RK20	RK20	RK20	RK20	RK40	RK40	RK40	RK40	RK60	RK80	RK120	RK160	RK240
<b>ISO</b>	F03/F05	F03/F05	F04	F04	F04	F04	F05/F07	F05/F07	F05/F07	F05/F07	F05/F07	F07/F10	F07/F10
<b>A</b>	153,7	153,7	153,7	153,7	180,4	180,4	180,4	180,4	215,4	235,5	265,9	285,9	318,4
<b>B</b>	9	11	9	11	11	14	11	14	14	17	17	22	22
<b>C x depth</b>	M5x8	M5x8	M5x8	M5x8	M5x8	M5x8	M6x9	M6x9	M6x9	M6x9	M6x9	M8x12	M8x12
<b>D x depth</b>	M6x9	M6x9	-	-	-	-	M8x12	M8x12	M8x12	M8x12	M8x12	M10x15	M10x15
<b>E</b>	36	36	42	42	42	42	50	50	50	50	50	70	70
<b>F</b>	50	50	-	-	-	-	70	70	70	70	70	102	102
<b>G</b>	10	10	10	10	13	13	13	13	13	13	13	13	19,5
<b>H</b>	50,9	50,9	50,9	50,9	60,8	60,8	60,8	60,8	68,7	75,6	87,6	97,5	112
<b>I</b>	9	9	9	9	12	12	12	12	12	15	15	19	22
<b>L</b>	100	100	100	100	112	112	112	112	122	130	143	154	180
<b>M</b>	30	30	30	30	36,5	36,5	36,5	36,5	41,5	46	51	56,5	64
<b>N</b>	82,5*	82,5*	82,5*	82,5*	95,5*	95,5*	95,5*	95,5*	107,8*	116,5*	127*	141*	159*
<b>O</b>	13,2	13,2	13,2	13,2	16,5	16,5	16,5	16,5	16,5	19,3	19,3	24,3	24,3
<b>P</b>	38,5*	38,5*	38,5*	38,5*	45*	45*	45*	45*	52,3*	56,5*	62*	70,5*	81*
<b>Q</b>	44	44	44	44	50,5	50,5	50,5	50,5	55,5	60	65	70,5	78
<b>R</b>	12,7	12,7	12,7	12,7	16,2	16,2	16,2	16,2	18	20,2	22,5	25,5	31,8
<b>S</b>	20	20	20	20	20	20	20	20	20	20	20	20	30
<b>T</b>	80	80	80	80	92	92	92	92	102	110	123	134	150
<b>U</b>	59,75	59,75	59,75	59,75	70,5	70,5	70,5	70,5	79	86	97,75	106,25	120,5
<b>V</b>	19	19	19	19	21	21	21	21	24	26	32	36	41
<b>W standard (GAS)</b>	1/8"	1/8"	1/8"	1/8"	1/8"	1/8"	1/8"	1/8"	1/8"	1/8"	1/4"	1/4"	1/4"
<b>W special (NPT)</b>	1/8"-27	1/8"-27	1/8"-27	1/8"-27	1/8"-27	1/8"-27	1/8"-27	1/8"-27	1/8"-27	1/8"-27	1/4"-18	1/4"-18	1/4"-18
<b>Ch.1</b>	10	10	10	10	10	10	10	10	13	13	13	16	18
<b>Ch.2</b>	3	3	3	3	3	3	3	3	4	4	4	5	6
<b>Weight (kg)</b>	1,5**	1,5**	1,5**	1,5**	2,3**	2,3**	2,3**	2,3**	3,2**	4,1**	5,7**	7,3**	10,2**
<b>Air (dm3/cycle)</b>	0,11	0,11	0,11	0,11	0,2	0,2	0,2	0,2	0,31	0,44	0,61	0,83	1,21
<b>Z</b>	59,9	59,9	59,9	59,9	69,8	69,8	69,8	69,8	77,7	84,6	96,6	106,6	121
<b>W</b>	1/8"	1/8"	1/8"	1/8"	1/8"	1/8"	1/8"	1/8"	1/8"	1/8"	1/4"	1/4"	1/4"

**H = CENTER OF PLATE'S FIXING.**

\* Variable according to adjustment.

\*\* Variable according to installed spring set.

**RK300 ÷ RK480**

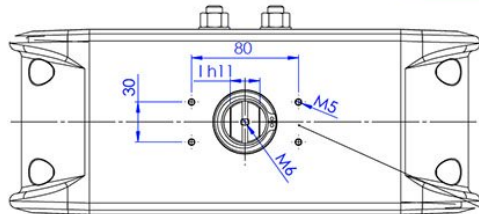
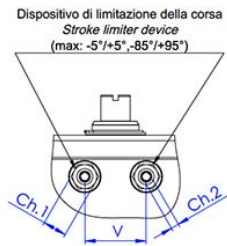
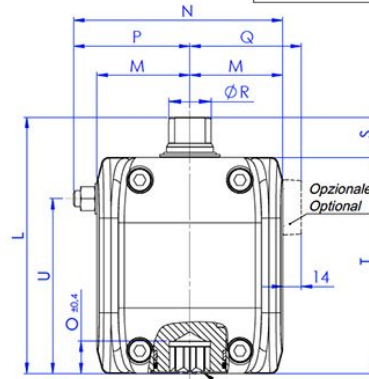
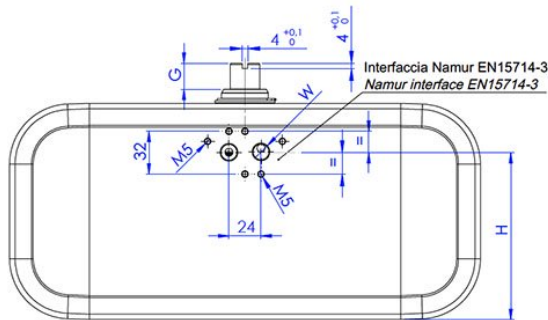
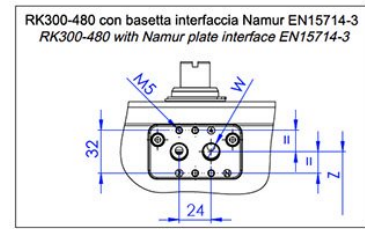
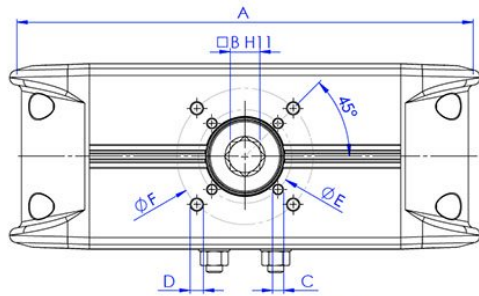

Anello di centraggio a richiesta  
 Centering ring on request

EN ISO 5211

Interfaccia per accessori secondo EN 15714-3 (VDI/VDE 3845)  
 Accessories interface EN 15714-3 (VDI/VDE 3845)

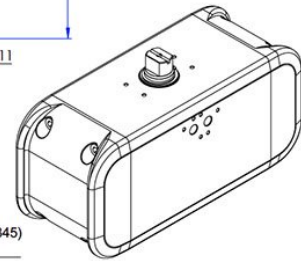



DIMENSIONS [mm]		
Size	<b>RK300</b>	<b>RK480</b>
<b>ISO</b>	F07/F10	F10/F12
<b>A</b>	352,4	393,4
<b>B</b>	22	27
<b>C x depth</b>	M8x12	M10x15
<b>D x depth</b>	M10x15	M12x18
<b>E</b>	70	102
<b>F</b>	102	125
<b>G</b>	19,5	19,5
<b>H</b>	125,6	145,6
<b>I</b>	22	27
<b>L</b>	192	214
<b>M</b>	69,5	80
<b>N</b>	156,5*	180*
<b>O</b>	24,3	29,5
<b>P</b>	87*	100*
<b>Q</b>	83,5	94
<b>R</b>	31,8	38
<b>S</b>	30	30
<b>T</b>	162	184
<b>U</b>	131	149,5
<b>V</b>	46	52
<b>W standard (GAS)</b>	1/4"	1/4"
<b>W special (NPT)</b>	1/4"-18	1/4"-18
<b>Ch.1</b>	18	21
<b>Ch.2</b>	6	6
<b>Weight (kg)</b>	13**	18,8**
<b>Air (dm<sup>3</sup>/cycle)</b>	1,56	2,46
<b>Z</b>	124,5	144,5
<b>W</b>	1/4"	1/4"

**H = CENTER OF PLATE'S FIXING.**

\* Variable according to adjustment.

\*\* Variable according to installed spring set.

materials

RK20 ÷ RK480

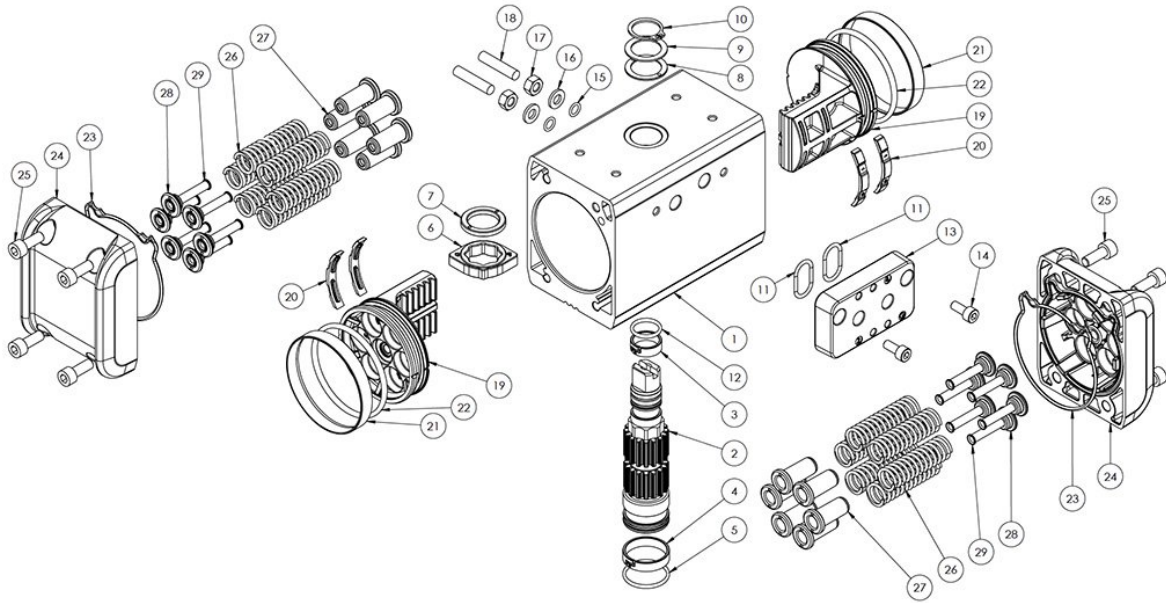

<b>MATERIALS</b>			
<b>Pos.</b>	<b>Description</b>	<b>Q.ty</b>	<b>Material</b>
1	Cylinder	1	Aluminium alloy
2	Shaft	1	Steel alloy
3*	Slide ring (upper shaft support)	1	Acetalic resins
4*	Slide ring (lower shaft support)	1	Acetalic resins
5*	O-ring (lower shaft sealing)	1	Nitrilic rubber
6	Cam	1	Steel alloy
7*	Internal support ring	1	Acetalic resins
8*	External support ring	1	Acetalic resins
9	Washer	1	Stainless steel
10*	Seeger	1	Stainless steel
11*	O-ring**	2	Nitrilic rubber
12*	O-ring (upper sealing shaft)	1	Nitrilic rubber
13	Namur plate**	1	Aluminium alloy
14	Screws**	2	Stainless steel
15*	O-ring	2	Nitrilic rubber
16*	Washer (limit stroke)	2	Stainless steel
17*	Hexagon nut (limit stroke)	2	Stainless steel
18*	Grub screw (limit stroke)	2	Stainless steel
19	Piston	2	Aluminium alloy
20*	Piston support leg	4	Acetalic resins
21*	Dynamic seal	2	Polyurethan
22*	O-ring	2	Nitrilic rubber
23*	End-cap O-ring	2	Nitrilic rubber
24	Cap	2	Aluminium alloy
25	Screws	8	Stainless steel
26	Spring	12	Steel alloy
27	Spring cartridge long	12	Acetalic resins
28	Spring cartridge short	12	Acetalic resins
29	Spring cartridge tube	12	Brass

\* Components of spare part kit.

\*\* Not present for some models, see code table.

The number of springs varies according to the model.

Excluded from the kit it is possible to request spare spring packs.



## diagrams and breakaway torque

"SR" N.C. OUTPUT TORQUE DIAGRAM (Nm)

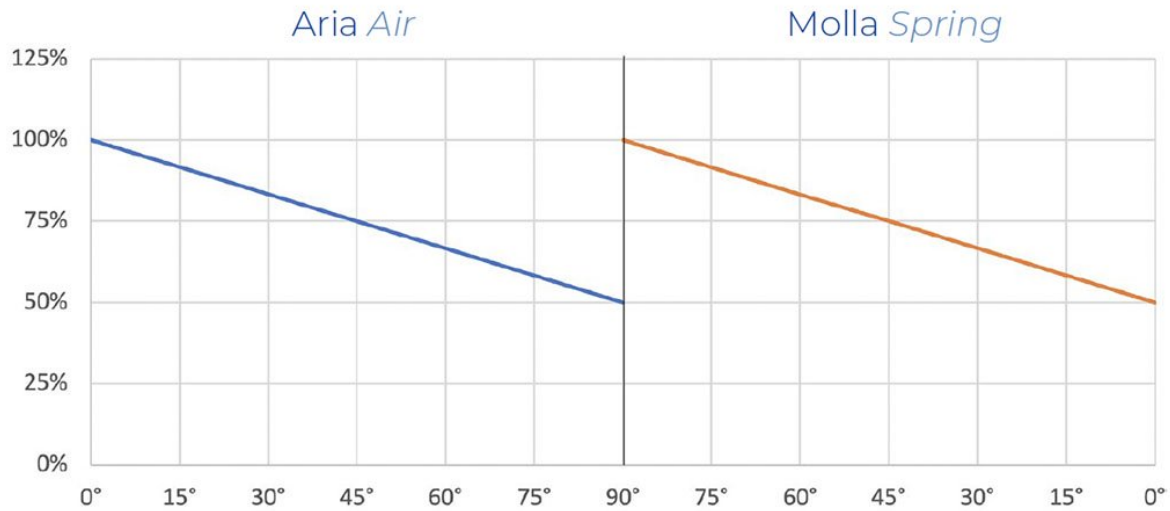

The graph is indicative; for torque values see the table below.

RACKON "SR" N.C. OUTPUT TORQUE TABLE (Nm)

Size	Spring	Air bar																						
		2 bar		2,5 bar		3 bar		3,5 bar		4 bar		4,5 bar		5 bar		5,5 bar		6 bar		7 bar		8 bar		
		0°	90°	0°	90°	0°	90°	0°	90°	0°	90°	0°	90°	0°	90°	0°	90°	0°	90°	0°	90°	0°	90°	
RK20	20	4,9	2,5	6,7	4,4	8,6	6,2	10,4	8,0	12,2	9,9	14,0	11,7	15,9	13,5	17,7	15,3	19,5	17,2	23,2	20,8	26,8		
	25	4,3	1,4	<b>6,1</b>	<b>3,2</b>	8,0	5,0	9,8	6,8	11,6	8,7	13,4	10,5	15,3	12,3	17,1	14,2	18,9	16,0	22,6	19,6	26,2		
	30			5,5	2,0	<b>7,4</b>	<b>3,8</b>	9,2	5,7	11,0	7,5	12,8	9,3	14,7	11,1	16,5	13,0	18,3	14,8	22,0	18,4	25,6		
	35					6,8	2,6	<b>8,6</b>	<b>4,5</b>	10,4	6,3	12,2	8,1	14,1	9,9	15,9	11,8	17,7	13,6	21,4	17,3	25,0		
	40							8,0	3,3	<b>9,8</b>	<b>5,1</b>	11,6	6,9	13,5	8,8	15,3	10,6	17,1	12,4	20,8	16,1	24,4		
	45									9,2	3,9	<b>11,0</b>	<b>5,7</b>	12,9	7,6	14,7	9,4	16,5	11,2	20,2	14,9	23,8		
	50											10,4	4,5	<b>12,3</b>	<b>6,4</b>	14,1	8,2	15,9	10,0	19,6	13,7	23,2		
	55														11,7	5,2	<b>13,5</b>	<b>7,0</b>	15,3	8,8	19,0	12,5	22,6	
	60																12,9	5,8	<b>14,7</b>	<b>7,6</b>	18,4	11,3	22,0	
RK40	20	9,3	4,8	12,8	8,3	16,3	11,8	19,8	15,3	23,3	18,8	26,7	22,3	30,2	25,7	33,7	29,2	37,2	32,7	44,1	39,7	51,1		
	25	8,2	2,6	<b>11,7</b>	<b>6,1</b>	15,1	9,5	18,6	13,0	22,1	16,5	25,6	20,0	29,1	23,5	32,6	27,0	36,0	30,4	43,0	37,4	50,0		
	30			10,5	3,8	<b>14,0</b>	<b>7,3</b>	17,5	10,8	21,0	14,2	24,4	17,7	27,9	21,2	31,4	24,7	34,9	28,2	41,8	35,1	48,8		
	35					12,8	5,0	<b>16,3</b>	<b>8,5</b>	19,8	12,0	23,3	15,4	26,8	18,9	30,3	22,4	33,7	25,9	40,7	32,9	47,7		
	40							15,2	6,2	<b>18,7</b>	<b>9,7</b>	22,1	13,2	25,6	16,7	29,1	20,1	32,6	23,6	39,5	30,6	46,5		
	45									17,5	7,4	<b>21,0</b>	<b>10,9</b>	24,5	14,4	28,0	17,9	31,4	21,4	38,4	28,3	45,4		
	50											19,8	8,6	<b>23,3</b>	<b>12,1</b>	26,8	15,6	30,3	19,1	37,2	26,0	44,2		
	55														22,2	9,8	<b>25,7</b>	<b>13,3</b>	29,1	16,8	36,1	23,8	43,1	
	60																24,5	11,1	<b>28,0</b>	<b>14,5</b>	34,9	21,5	41,9	
RK60	20	14,2	7,4	19,5	12,7	24,9	18,1	30,2	23,4	35,5	28,7	40,8	34,0	46,1	39,3	51,4	44,6	56,7	49,9	67,3	60,5	77,9		
	25	12,5	4,0	<b>17,8</b>	<b>9,3</b>	23,1	14,6	28,4	19,9	33,7	25,2	39,0	30,5	44,3	35,8	49,7	41,2	55,0	46,5	65,6	57,1	76,2		
	30			16,0	5,8	<b>21,4</b>	<b>11,2</b>	26,7	16,5	32,0	21,8	37,3	27,1	42,6	32,4	47,9	37,7	53,2	43,0	63,8	53,6	74,4		
	35					19,6	7,7	<b>24,9</b>	<b>13,0</b>	30,2	18,3	35,5	23,6	40,8	28,9	46,2	34,3	51,5	39,6	62,1	50,2	72,7		
	40							23,2	9,6	<b>28,5</b>	<b>14,9</b>	33,8	20,2	39,1	25,5	44,4	30,8	49,7	36,1	60,3	46,7	70,9		
	45									26,7	11,4	<b>32,0</b>	<b>16,7</b>	37,3	22,0	42,7	27,4	48,0	32,7	58,6	43,3	69,2		
	50											30,3	13,3	<b>35,6</b>	<b>18,6</b>	40,9	23,9	46,2	29,2	56,8	39,8	67,4		
	55														33,8	15,1	<b>39,2</b>	<b>20,5</b>	44,5	25,8	55,1	36,4	65,7	

	60																	37,4	17,0	<b>42,7</b>	<b>22,3</b>	53,3	32,9	63,9
RK80	20	20,1	10,5	27,6	18,0	35,1	25,5	42,6	33,0	50,0	40,4	57,5	47,9	65,0	55,4	72,5	62,9	80,0	70,4	95,0	85,4	110,0		
	25	17,6	5,6	<b>25,1</b>	<b>13,1</b>	32,6	20,6	40,1	28,1	47,6	35,6	55,1	43,1	62,6	50,6	70,1	58,1	77,5	65,5	92,5	80,5	107,5		
	30			22,6	8,2	<b>30,1</b>	<b>15,7</b>	37,6	23,2	45,1	30,7	52,6	38,2	60,1	45,7	67,6	53,2	75,1	60,7	90,1	75,7	105,0		
	35					27,7	10,9	<b>35,1</b>	<b>18,3</b>	42,6	25,8	50,1	33,3	57,6	40,8	65,1	48,3	72,6	55,8	87,6	70,8	102,6		
	40							32,7	13,5	<b>40,2</b>	<b>21,0</b>	47,7	28,5	55,1	35,9	62,6	43,4	70,1	50,9	85,1	65,9	100,1		
	45									37,7	16,1	<b>45,2</b>	<b>23,6</b>	52,7	31,1	60,2	38,6	67,7	46,1	82,6	61,0	97,6		
	50											42,7	18,7	<b>50,2</b>	<b>26,2</b>	57,7	33,7	65,2	41,2	80,2	56,2	95,2		
	55													47,7	21,3	<b>55,2</b>	<b>28,8</b>	62,7	36,3	77,7	51,3	92,7		
	60															52,8	24,0	<b>60,3</b>	<b>31,5</b>	75,2	46,4	90,2		
RK120	20	28,7	14,9	39,3	25,6	50,0	36,3	60,7	46,9	71,3	57,6	82,0	68,3	92,7	79,0	103,4	89,6	114,0	100,3	135,4	121,7	156,7		
	25	25,1	8,0	<b>35,8</b>	<b>18,7</b>	46,5	29,3	57,2	40,0	67,8	50,7	78,5	61,4	89,2	72,0	99,9	82,7	110,5	93,4	131,9	114,7	153,2		
	30			32,3	11,7	<b>43,0</b>	<b>22,4</b>	53,6	33,1	64,3	43,7	75,0	54,4	85,7	65,1	96,3	75,8	107,0	86,4	128,4	107,8	149,7		
	35					39,5	15,5	<b>50,1</b>	<b>26,1</b>	60,8	36,8	71,5	47,5	82,2	58,1	92,8	68,8	103,5	79,5	124,8	100,8	146,2		
	40							46,6	19,2	<b>57,3</b>	<b>29,9</b>	68,0	40,5	78,6	51,2	89,3	61,9	100,0	72,6	121,3	93,9	142,7		
	45									53,8	22,9	<b>64,5</b>	<b>33,6</b>	75,1	44,3	85,8	54,9	96,5	65,6	117,8	87,0	139,2		
	50											61,0	26,7	<b>71,6</b>	<b>37,3</b>	82,3	48,0	93,0	58,7	114,3	80,0	135,7		
	55													68,1	30,4	<b>78,8</b>	<b>41,1</b>	89,5	51,7	110,8	73,1	132,2		
	60															75,3	34,1	<b>86,0</b>	<b>44,8</b>	107,3	66,1	128,6		
RK160	20	39,3	20,5	53,9	35,1	68,6	49,7	83,2	64,4	97,9	79,0	112,5	93,6	127,1	108,3	141,8	122,9	156,4	137,6	185,7	166,8	214,9		
	25	34,5	37,6	<b>49,1</b>	<b>25,6</b>	63,8	40,2	78,4	54,9	93,0	69,5	107,7	84,1	122,3	98,8	137,0	113,4	151,6	128,0	180,9	157,3	210,1		
	30			44,3	16,1	<b>59,0</b>	<b>30,7</b>	73,6	45,3	88,2	60,0	102,9	74,6	117,5	89,2	132,1	103,9	146,8	118,5	176,0	147,8	205,3		
	35					54,1	21,2	<b>68,8</b>	<b>35,8</b>	83,4	50,5	98,1	65,1	112,7	79,7	127,3	94,4	142,0	109,0	171,2	138,3	200,5		
	40							64,0	26,3	<b>78,6</b>	<b>40,9</b>	93,2	55,6	107,9	70,2	122,5	84,8	137,2	99,5	166,4	128,7	195,7		
	45									73,8	31,4	<b>88,4</b>	<b>46,0</b>	103,1	60,7	117,7	75,3	132,3	90,0	161,6	119,2	190,9		
	50											83,6	36,5	<b>98,3</b>	<b>51,2</b>	112,9	65,8	127,5	80,4	156,8	109,7	186,1		
	55													93,5	41,6	<b>108,1</b>	<b>56,3</b>	122,7	70,9	152,0	100,2	181,3		
	60															103,3	46,8	<b>117,9</b>	<b>61,4</b>	147,2	90,7	176,5		
RK240	20	57,2	29,8	78,5	51,1	99,8	72,4	121,1	93,7	142,4	115,0	163,7	136,3	185,0	157,6	206,3	178,9	227,6	200,2	270,2	242,8	312,8		
	25	50,2	16,0	<b>71,5</b>	<b>37,3</b>	92,8	58,6	114,1	79,9	135,4	101,2	156,7	122,5	178,0	143,8	199,3	165,1	220,6	186,4	263,2	229,0	305,8		
	30			64,5	23,5	<b>85,8</b>	<b>44,8</b>	107,1	66,1	128,4	87,4	149,7	108,7	171,0	130,0	192,3	151,3	213,6	172,6	256,2	215,2	298,8		
	35					78,8	30,9	<b>100,1</b>	<b>52,2</b>	121,4	73,5	142,7	94,8	164,0	116,1	185,3	137,4	206,6	158,7	249,2	201,3	291,8		
	40							93,1	38,4	<b>114,4</b>	<b>59,7</b>	135,7	81,0	157,0	102,3	178,3	123,6	199,6	144,9	242,2	187,5	284,8		
	45									107,4	45,8	<b>128,7</b>	<b>67,1</b>	150,0	88,4	171,3	109,7	192,6	131,0	235,2	173,6	277,8		
	50											121,7	53,3	<b>143,0</b>	<b>74,6</b>	164,3	95,9	185,6	117,2	228,2	159,8	270,8		
	55													136,0	60,8	<b>157,3</b>	<b>82,1</b>	178,6	103,4	221,2	146,0	263,8		
	60															150,3	68,2	<b>171,6</b>	<b>89,5</b>	214,2	132,1	256,8		
RK300	20	73,7	38,4	101,1	65,9	128,6	93,3	156,0	120,8	183,4	148,2	210,9	175,6	238,3	203,1	265,8	230,5	293,2	258,0	348,1	312,9	403,0		
	25	64,6	20,6	<b>92,1</b>	<b>48,0</b>	119,5	75,5	147,0	102,9	174,4	130,4	201,9	157,8	229,3	185,3	256,8	212,7	284,2	240,1	339,1	295,0	394,0		
	30			83,0	30,2	<b>110,5</b>	<b>57,6</b>	137,9	85,1	165,4	112,5	192,8	140,0	220,3	167,4	247,7	194,9	275,2	222,3	330,1	277,2	384,9		
	35					101,5	39,8	<b>128,9</b>	<b>67,2</b>	156,4	94,7	183,8	122,1	211,2	149,6	238,7	177,0	266,1	204,5	321,0	259,4	375,9		
	40							119,9	49,4	<b>147,3</b>	<b>76,8</b>	174,8	104,3	202,2	131,7	229,7	159,2	257,1	186,6	312,0	241,5	366,9		
	45									138,3	59,0	<b>165,7</b>	<b>86,4</b>	193,2	113,9	220,6	141,3	248,1	168,8	303,0	223,7	357,9		
	50											156,7	68,6	<b>184,2</b>	<b>96,1</b>	211,6	123,5	239,0	150,9	293,9	205,8	348,8		
	55													175,1	78,2	<b>202,6</b>	<b>105,7</b>	230,0	133,1	284,9	188,0	339,8		
	60															193,5	87,8	<b>221,0</b>	<b>115,3</b>	275,9	170,2	330,8		
RK480	20	115,7	60,3	158,8	103,4	201,9	146,5	245,0	189,6	288,0	232,7	331,1	275,8	374,2	318,9	417,3	362,0	460,4	405,1	546,6	491,2	632,8		
	25	101,5	32,3	<b>144,6</b>	<b>75,4</b>	187,7	118,5	230,8	161,6	273,9	204,7	317,0	247,8	360,1	290,9	403,2	334,0	446,2	377,0	532,4	463,2	618,6		
	30			130,4	47,4	<b>173,5</b>	<b>90,5</b>	216,6	133,6	259,7	176,7	302,8	219,8	345,9	262,8	389,0	305,9	432,1	349,0	518,3	435,2	604,4		
	35					159,4	62,5	<b>202,4</b>	<b>105,6</b>	245,5	148,7	288,6	191,7	331,7	234,8	374,8	277,9	417,9	321,0	504,1	407,2	590,3		
	40							188,3	77,6	<b>231,4</b>	<b>120,6</b>	274,5	163,7	317,5	206,8	360,6	249,9	403,7	293,0	489,9	379,2	576,1		
	45									217,2	92,6	<b>260,3</b>	<b>135,7</b>	303,4	178,8	346,5	221,9	389,6	265,0	475,7	351,2	561,9		



<b>RK60</b>	40								23,2	9,6	<b>28,5</b>	<b>14,9</b>		33,8	20,2	39,1	25,5	44,4	30,8	49,7	36,1	60,3	46,7	70,9
	45										26,7	11,4		<b>32,0</b>	<b>16,7</b>	37,3	22,0	42,7	27,4	48,0	32,7	58,6	43,3	69,2
	50													30,3	13,3	<b>35,6</b>	<b>18,6</b>	40,9	23,9	46,2	29,2	56,8	39,8	67,4
	55															33,8	15,1	<b>39,2</b>	<b>20,5</b>	44,5	25,8	55,1	36,4	65,7
	60																	37,4	17,0	<b>42,7</b>	<b>22,3</b>	53,3	32,9	63,9
<b>RK80</b>	20	20,1	10,5	27,6	18,0	35,1	25,5	42,6	33,0	50,0	40,4	57,5	47,9	65,0	55,4	72,5	62,9	80,0	70,4	95,0	85,4	110,0		
	25	17,6	5,6	<b>25,1</b>	<b>13,1</b>	32,6	20,6	40,1	28,1	47,6	35,6	55,1	43,1	62,6	50,6	70,1	58,1	77,5	65,5	92,5	80,5	107,5		
	30			22,6	8,2	<b>30,1</b>	<b>15,7</b>	37,6	23,2	45,1	30,7	52,6	38,2	60,1	45,7	67,6	53,2	75,1	60,7	90,1	75,7	105,0		
	35					27,7	10,9	<b>35,1</b>	<b>18,3</b>	42,6	25,8	50,1	33,3	57,6	40,8	65,1	48,3	72,6	55,8	87,6	70,8	102,6		
	40							32,7	13,5	<b>40,2</b>	<b>21,0</b>	47,7	28,5	55,1	35,9	62,6	43,4	70,1	50,9	85,1	65,9	100,1		
	45									37,7	16,1	<b>45,2</b>	<b>23,6</b>	52,7	31,1	60,2	38,6	67,7	46,1	82,6	61,0	97,6		
	50											42,7	18,7	<b>50,2</b>	<b>26,2</b>	57,7	33,7	65,2	41,2	80,2	56,2	95,2		
<b>RK120</b>	20	28,7	14,9	39,3	25,6	50,0	36,3	60,7	46,9	71,3	57,6	82,0	68,3	92,7	79,0	103,4	89,6	114,0	100,3	135,4	121,7	156,7		
	25	25,1	8,0	<b>35,8</b>	<b>18,7</b>	46,5	29,3	57,2	40,0	67,8	50,7	78,5	61,4	89,2	72,0	99,9	82,7	110,5	93,4	131,9	114,7	153,2		
	30			32,3	11,7	<b>43,0</b>	<b>22,4</b>	53,6	33,1	64,3	43,7	75,0	54,4	85,7	65,1	96,3	75,8	107,0	86,4	128,4	107,8	149,7		
	35					39,5	15,5	<b>50,1</b>	<b>26,1</b>	60,8	36,8	71,5	47,5	82,2	58,1	92,8	68,8	103,5	79,5	124,8	100,8	146,2		
	40							46,6	19,2	<b>57,3</b>	<b>29,9</b>	68,0	40,5	78,6	51,2	89,3	61,9	100,0	72,6	121,3	93,9	142,7		
	45									53,8	22,9	<b>64,5</b>	<b>33,6</b>	75,1	44,3	85,8	54,9	96,5	65,6	117,8	87,0	139,2		
	50											61,0	26,7	<b>71,6</b>	<b>37,3</b>	82,3	48,0	93,0	58,7	114,3	80,0	135,7		
<b>RK160</b>	20	39,3	20,5	53,9	35,1	68,6	49,7	83,2	64,4	97,9	79,0	112,5	93,6	127,1	108,3	141,8	122,9	156,4	137,6	185,7	166,8	214,9		
	25	34,5	37,6	<b>49,1</b>	<b>25,6</b>	63,8	40,2	78,4	54,9	93,0	69,5	107,7	84,1	122,3	98,8	137,0	113,4	151,6	128,0	180,9	157,3	210,1		
	30			44,3	16,1	<b>59,0</b>	<b>30,7</b>	73,6	45,3	88,2	60,0	102,9	74,6	117,5	89,2	132,1	103,9	146,8	118,5	176,0	147,8	205,3		
	35					54,1	21,2	<b>68,8</b>	<b>35,8</b>	83,4	50,5	98,1	65,1	112,7	79,7	127,3	94,4	142,0	109,0	171,2	138,3	200,5		
	40							64,0	26,3	<b>78,6</b>	<b>40,9</b>	93,2	55,6	107,9	70,2	122,5	84,8	137,2	99,5	166,4	128,7	195,7		
	45									73,8	31,4	<b>88,4</b>	<b>46,0</b>	103,1	60,7	117,7	75,3	132,3	90,0	161,6	119,2	190,9		
	50											83,6	36,5	<b>98,3</b>	<b>51,2</b>	112,9	65,8	127,5	80,4	156,8	109,7	186,1		
<b>RK240</b>	20	57,2	29,8	78,5	51,1	99,8	72,4	121,1	93,7	142,4	115,0	163,7	136,3	185,0	157,6	206,3	178,9	227,6	200,2	270,2	242,8	312,8		
	25	50,2	16,0	<b>71,5</b>	<b>37,3</b>	92,8	58,6	114,1	79,9	135,4	101,2	156,7	122,5	178,0	143,8	199,3	165,1	220,6	186,4	263,2	229,0	305,8		
	30			64,5	23,5	<b>85,8</b>	<b>44,8</b>	107,1	66,1	128,4	87,4	149,7	108,7	171,0	130,0	192,3	151,3	213,6	172,6	256,2	215,2	298,8		
	35					78,8	30,9	<b>100,1</b>	<b>52,2</b>	121,4	73,5	142,7	94,8	164,0	116,1	185,3	137,4	206,6	158,7	249,2	201,3	291,8		
	40							93,1	38,4	<b>114,4</b>	<b>59,7</b>	135,7	81,0	157,0	102,3	178,3	123,6	199,6	144,9	242,2	187,5	284,8		
	45									107,4	45,8	<b>128,7</b>	<b>67,1</b>	150,0	88,4	171,3	109,7	192,6	131,0	235,2	173,6	277,8		
	50											121,7	53,3	<b>143,0</b>	<b>74,6</b>	164,3	95,9	185,6	117,2	228,2	159,8	270,8		
<b>RK300</b>	20	73,7	38,4	101,1	65,9	128,6	93,3	156,0	120,8	183,4	148,2	210,9	175,6	238,3	203,1	265,8	230,5	293,2	258,0	348,1	312,9	403,0		
	25	64,6	20,6	<b>92,1</b>	<b>48,0</b>	119,5	75,5	147,0	102,9	174,4	130,4	201,9	157,8	229,3	185,3	256,8	212,7	284,2	240,1	339,1	295,0	394,0		
	30			83,0	30,2	<b>110,5</b>	<b>57,6</b>	137,9	85,1	165,4	112,5	192,8	140,0	220,3	167,4	247,7	194,9	275,2	222,3	330,1	277,2	384,9		
	35					101,5	39,8	<b>128,9</b>	<b>67,2</b>	156,4	94,7	183,8	122,1	211,2	149,6	238,7	177,0	266,1	204,5	321,0	259,4	375,9		
	40							119,9	49,4	<b>147,3</b>	<b>76,8</b>	174,8	104,3	202,2	131,7	229,7	159,2	257,1	186,6	312,0	241,5	366,9		
	45									138,3	59,0	<b>165,7</b>	<b>86,4</b>	193,2	113,9	220,6	141,3	248,1	168,8	303,0	223,7	357,9		
	50											156,7	68,6	<b>184,2</b>	<b>96,1</b>	211,6	123,5	239,0	150,9	293,9	205,8	348,8		
	55													175,1	78,2	<b>202,6</b>	<b>105,7</b>	230,0	133,1	284,9	188,0	339,8		
	60															193,5	87,8	<b>221,0</b>	<b>115,3</b>	275,9	170,2	330,8		
	20	115,7	60,3	158,8	103,4	201,9	146,5	245,0	189,6	288,0	232,7	331,1	275,8	374,2	318,9	417,3	362,0	460,4	405,1	546,6	491,2	632,8		
	25	101,5	32,3	<b>144,6</b>	<b>75,4</b>	187,7	118,5	230,8	161,6	273,9	204,7	317,0	247,8	360,1	290,9	403,2	334,0	446,2	377,0	532,4	463,2	618,6		



RK480	30			130,4	47,4	<b>173,5</b>	<b>90,5</b>	216,6	133,6	259,7	176,7	302,8	219,8	345,9	262,8	389,0	305,9	432,1	349,0	518,3	435,2	604,4	
	35					159,4	62,5	<b>202,4</b>	<b>105,6</b>	245,5	148,7	288,6	191,7	331,7	234,8	374,8	277,9	417,9	321,0	504,1	407,2	590,3	
	40							188,3	77,6	<b>231,4</b>	<b>120,6</b>	274,5	163,7	317,5	206,8	360,6	249,9	403,7	293,0	489,9	379,2	576,1	
	45										217,2	92,6	<b>260,3</b>	<b>135,7</b>	303,4	178,8	346,5	221,9	389,6	265,0	475,7	351,2	561,9
	50												246,1	107,7	<b>289,2</b>	<b>150,8</b>	332,3	193,9	375,4	237,0	461,6	323,2	547,8
	55														275,0	122,8	<b>318,1</b>	<b>165,9</b>	361,2	209,0	447,4	295,2	533,6
	60															304,0	137,9	<b>347,1</b>	<b>181,0</b>	433,2	267,2	519,4	

## specifications

### SPRING RETURN ACTUATOR N.C. WORKING PLANE

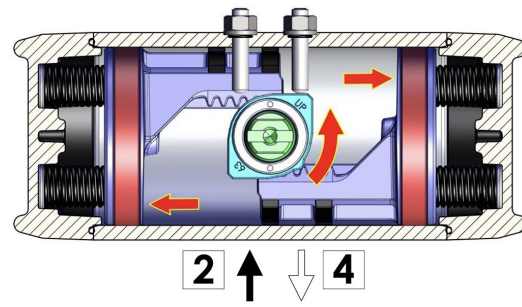
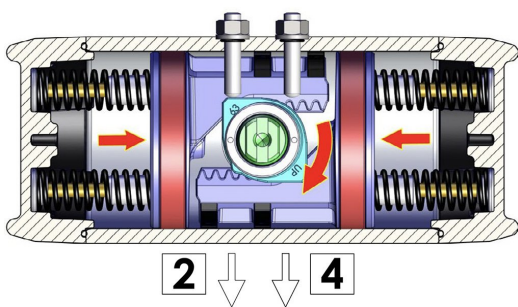

### WORKING PLANE

Without air supply, the spring return actuator returns to its resting position, and shaft rotate in a clockwise direction. The drawing shows its final position. We advise to assemble a small filter on the air connection 4 to prevent dust and particles into the cylinder chamber without, however, preventing the passage of air.

### WORKING PLANE

Supplying air through the air connection 2, the pistons move outwards pressing the spring. The shaft rotate in a counter-clockwise direction takes place and the final position is shown above.

### SPRING RETURN ACTUATOR N.O. WORKING PLANE

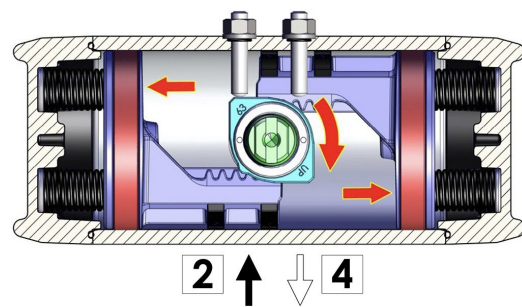
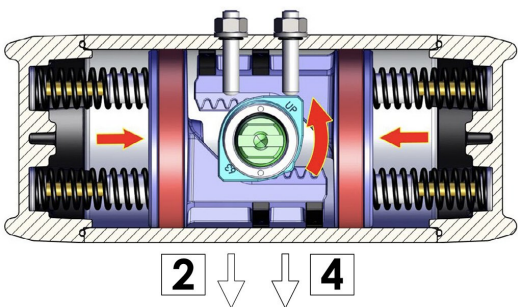



**WORKING PLANE**

Without air supply, the spring return actuator returns to its resting position, and shaft rotate in a counter-clockwise direction. The drawing shows its final position. We advise to assemble a small filter on the air connection 4 to prevent dust and particles into the cylinder chamber without, however, preventing the passage of air.

**WORKING PLANE**

Supplying air through the air connection 2, the pistons move outwards pressing the spring. The shaft rotate in a clockwise direction takes place and the final position is shown above.

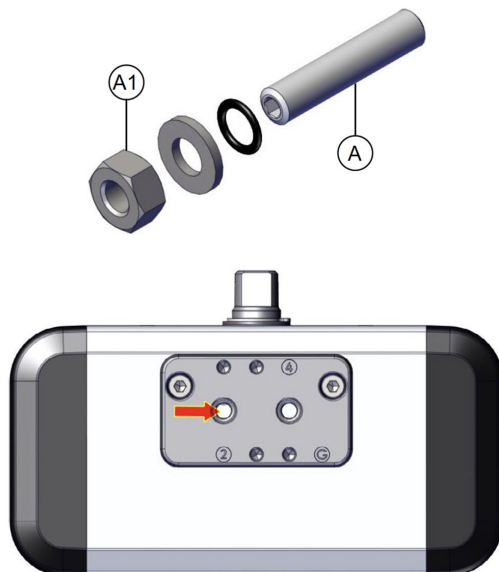
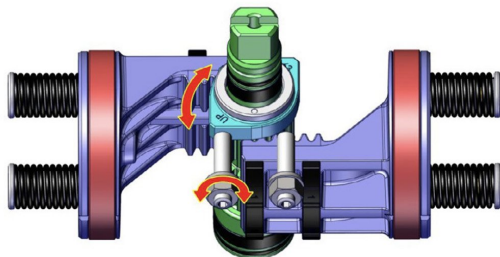
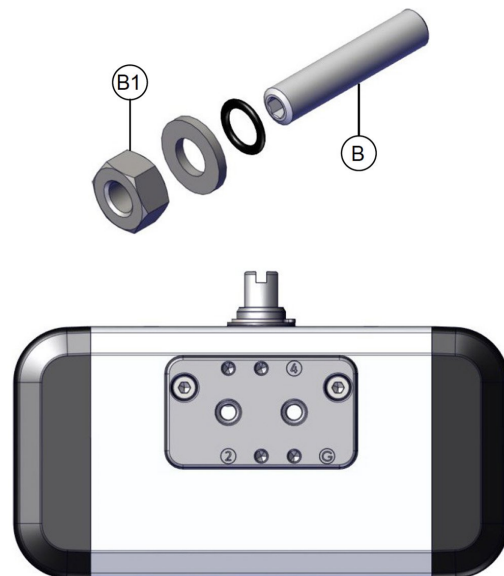
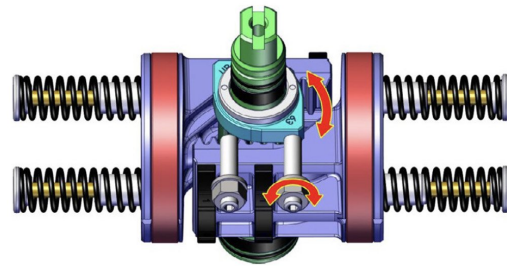
**INSTRUCTIONS FOR ADJUSTING THE STROKE OF THE SR ACTUATOR N.C.**
**OPENING ADJUSTMENT**

**CLOSING ADJUSTMENT**

- A) Check that the filter is mounted on hole 4 and that it is not blocked. Check that there is no pressurized air in the actuator (in both chambers).
- B) Loosen locknut A1.
- C) Supply air to hole "2" (sufficient only for movement) the pistons will be in the end of stroke.
- D) Screw or unscrew the screw A with an Allen key for the desired adjustment (maximum adjustment range  $\pm 5^\circ$ ).
- E) Once the adjustment has been made, with an Allen key stop the screw A, at the same time with a wrench tighten the locknut A1.

N.B. If necessary, repeat the operations until the desired setting is obtained.

- A) Check that there is no pressurized air in the actuator (in both chambers).
- B) Loosen locknut B1.
- C) Screw or unscrew the screw B with an Allen key for the desired adjustment (maximum adjustment range  $\pm 5^\circ$ ).
- D) Once the adjustment has been made, with an Allen key stop the screw B, at the same time with a wrench tighten the locknut B1.

N.B. If necessary, repeat the operations until the desired setting is obtained.

#### INSTRUCTIONS FOR ADJUSTING THE STROKE OF THE SR ACTUATOR N.O.

##### OPENING ADJUSTMENT

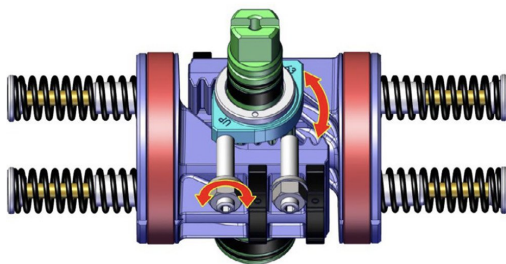

##### CLOSING ADJUSTMENT

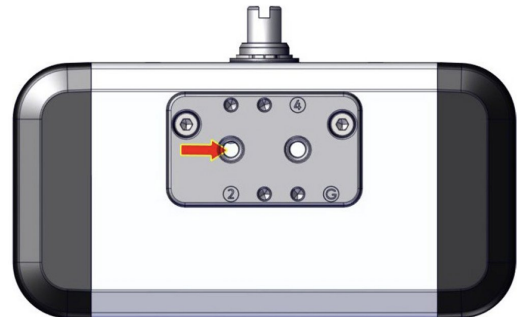
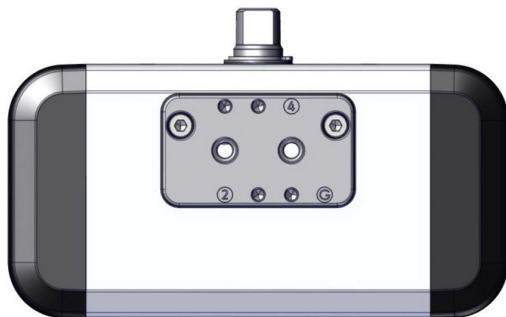
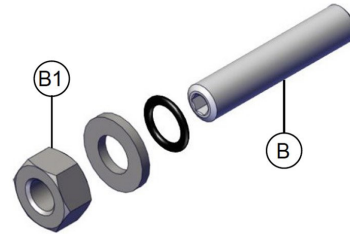
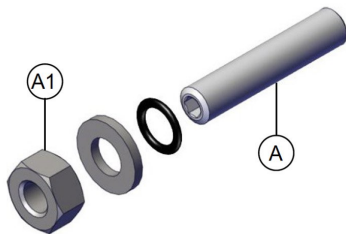
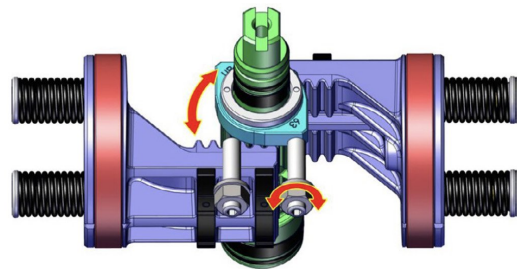

- A) Check that there is no pressurized air in the actuator (in both chambers).
- B) Remove the supply air.
- C) Loosen locknut A1.
- D) Screw or unscrew the screw A with an Allen key for the desired adjustment (maximum adjustment range  $\pm 5^\circ$ ).
- E) Once the adjustment has been made, with an Allen key stop the screw A, at the same time with a wrench tighten the locknut A1.

N.B. If necessary, repeat the operations until the desired setting is obtained.

- A) Check that the filter is mounted on hole 4 and that it is not blocked. Check that there is no pressurized air in the actuator (in both chambers).
- B) Loosen locknut B1.
- C) Supply air to hole "2" (sufficient only for movement) the pistons will be in the end of stroke.
- D) Screw or unscrew the screw B with an Allen key for the desired adjustment (maximum adjustment range  $\pm 5^\circ$ ).
- E) Once the adjustment has been made, with an Allen key stop the screw B, at the same time with a wrench tighten the locknut B1.

N.B. If necessary, repeat the operations until the desired setting is obtained.

## documents

### Instructions

[APRK1219 - User Manual RACKON](#)

### Manuals

[Instruction manual UMAAPRK0](#)

### Certificates

[SIL3 IEC 61508 - RACKON](#)

[Degrees of protection provided by enclosures IP66-X7](#)

[Degrees of protection provided by enclosures IP 6X - IP X8](#)

[ATEX - Rack & Pinion pneumatic actuators](#)

