

DA008401S

Pneumatic actuators - AGO - Aluminium
 actuators DA08 F03

Size: DA08
 ISO: F03

81,50 € Excl. VAT
 list price



Article	Weight [kg]	Torque 5,6 bar [Nm]	Air volume [dm ³ /cycle]	Spare seal
DA008401S	0.29	8 Nm	0.034	KGD10010

GENERAL INFO

AGO - Aluminium double acting DA type

benefits

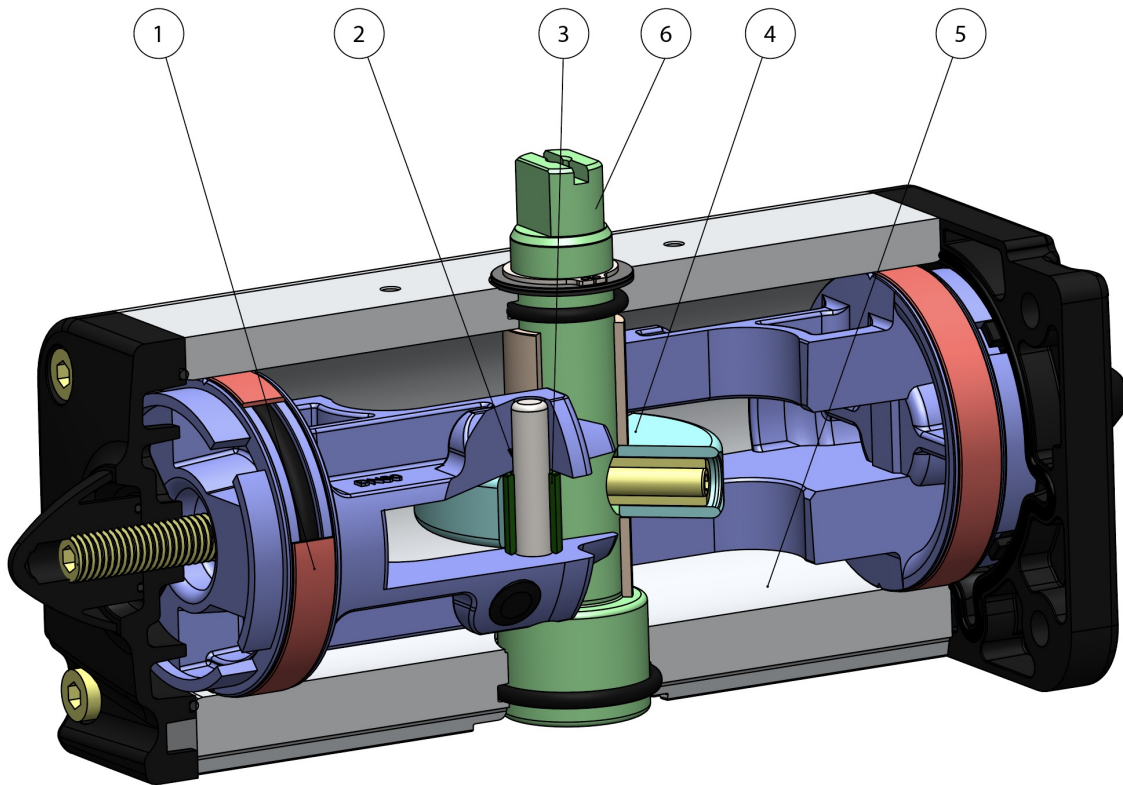

1. Energized and self-lubricated strips

Less friction between piston and cylinder
It prevents the bonding of the seal to the cylinder even after long periods of inactivity

2. Slots, bushes and pins made by steel with hardness higher than 50 HRC

Higher resistance to the forces inside the actuator

3. Rolling friction between piston and slot

Less friction

4. Scotch yoke with rolling friction (transforming rotary motion into linear motion using piston and shaft without teeth/gears)

Reduced friction between piston and shaft with consequently less wear on the relevant parts
Empowered Breakaway Torque (BTO & BTC)
Smaller volume/size than rack and pinion actuators (with the same torque) therefore less space required for installation
Less weight than the rack and pinion (-30% kg / Nm), with consequent savings on the construction sizing of the plant/equipment
Lower air consumption compared to the rack and pinion actuators (-40% air cm³/Nm for Double Acting and -20% air cm³/Nm for Spring Return) therefore less load on the compressor or the possibility of using a smaller compressor's size.

5. Rolled cylinder

Less wear of the energized ties thanks to the low roughness of the surface

6. Stainless Steel shaft

Higher corrosion resistance

From sizes bigger than DAN15, NAMUR interface for solenoid valve is already integrated.

No need for extra plate.

100% in- house manufacturing process technology

Maximum control and accuracy in all the stages of the manufacturing process

ATEX Certificate

Installation is allowed in a potential explosive environment

Up to SIL 3 Certified

Guarantee of the high level of functional safety.

features

TECHNICAL FEATURES

Torque from 8 Nm to 8000 Nm.
Mounting flange according to EN ISO 5211
F03 - F04 - F05 - F07 - F10 - F12 - F14 - F16 - F25.
In accordance with EN 15714-3
Rotation angle: 92° (-1°, +91°)
Torque: directly proportional to the air supply (see table).
The code numbers after the DA/DAN letters, always correspond to the breakaway torque in Nm by 5,6 bar air supply.
ATEX version in conformity with directive 2014/34/EU. Please add
YX at the end of the code for ATEX version.

WORKING CONDITIONS

Temperature: from -20°C to +80°C. (Special versions: high temperature: -20°C +150°C; low temperature: -50°C +60°)
Air supply: 5,6 bar; maximum 8,4 bar (7 bar for DA8000).
Actuating media: filtered dry compressed air, not necessarily lubricated.
In case of lubricated air, either non detergent oil, NBR compatible oil, must be used.

dimensions

DA08**Double acting pneumatic actuator size DA08 (Nm)**

dimensions

DATA SHEET DA08 (Nm)	
Code	DA008401S
Weight [Kg]	0,29
Air volume [dm ³ /cycle]	0,034
Spare seals	KGDI0010

dimensions

DAN15 - DAN1920

Double acting pneumatic actuator sizes from DAN15 (Nm) to DAN1920 (Nm)

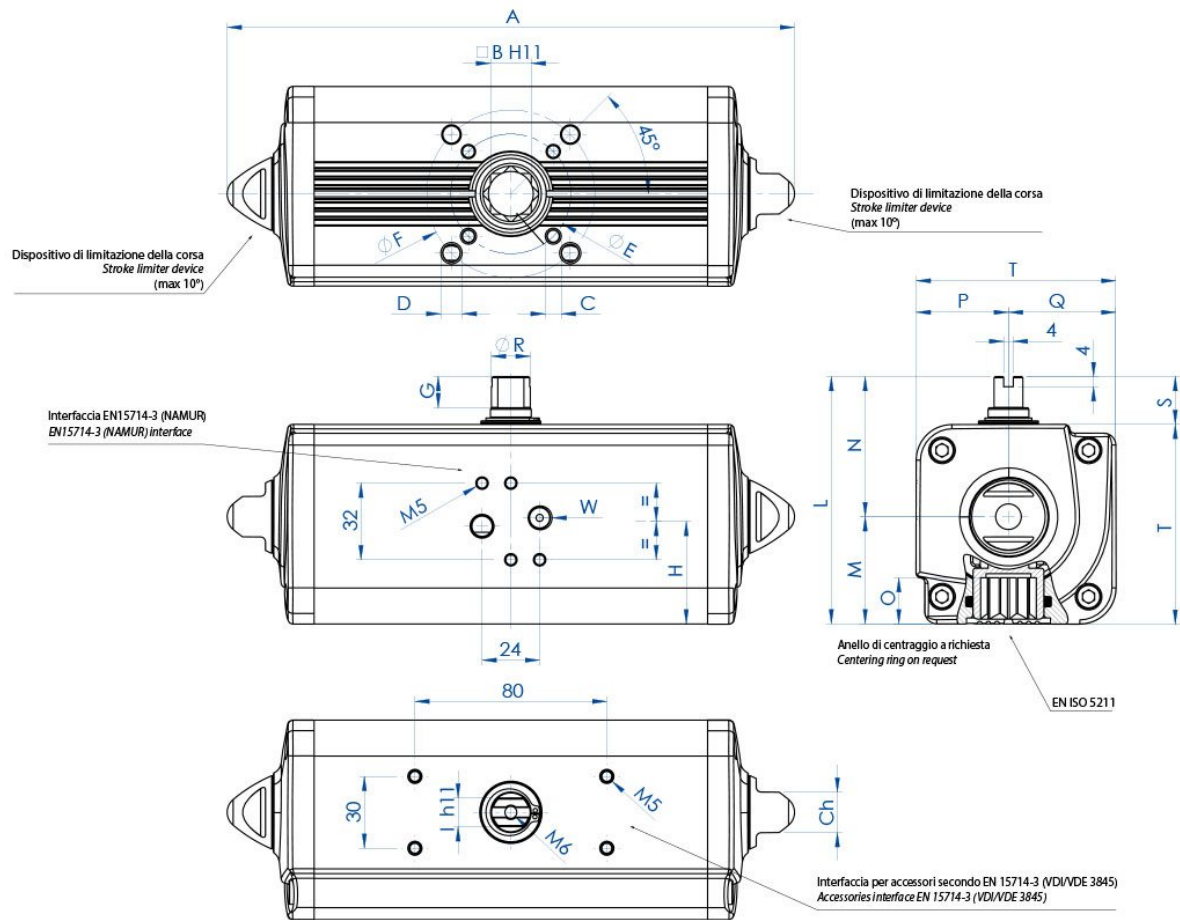

dimensions

DATA SHEET from DAN15 (Nm) to DAN60 (Nm)								
Code	DAN0015411S	DAN0015412S	DAN0030411S	DAN0030412S	DAN0045411S	DAN0045412S	DAN0060411S	DAN0060412S
Spare seals	KGGI0012		KGGI0014		KGGI0015		KGGI0016	
Size	DAN15		DAN30		DAN45		DAN60	
ISO	F03	F04	F03/F05	F04	F04	F03/F05	F04	F05/F07
A	159,1	159,1	174,3	174,3	188,5	188,5	198,1	198,1
B	11	11	11	11	11	11	14	14
C x depth	M5x8	M5x8	M5x8	M5x8	M5x8	M5x8	M5x8	M6x9
D x depth	-	-	M6x9	-	-	M6x9	-	M8x12
E	36	42	36	42	42	36	42	50
F	-	-	50	-	-	50	-	70
G	10	10	10	10	13	13	13	13
H	26,8	26,8	30,3	30,3	32,5	32,5	35,7	35,7
I	8	8	9	9	10	10	10	10
L	72,2	72,2	79,2	79,2	84,5	84,5	90,4	90,4
M	28	28	31,5	31,5	34,5	34,5	37,7	37,7
N	44,2	44,2	47,7	47,7	50	50	52,7	52,7
O	13,2	13,2	13,2	13,2	13,2	13,2	16,5	16,5
P	24,2	24,2	27,7	27,7	30	30	32,7	32,7
Q	28	28	31,5	31,5	34,5	34,5	37,7	37,7
R	9,2	9,2	10,9	10,9	12,7	12,7	14,5	14,5
S	20	20	20	20	20	20	20	20
T	52,2	52,2	59,2	59,2	64,5	64,5	70,4	70,4
W (Gas)	1/8"	1/8"	1/8"	1/8"	1/8"	1/8"	1/8"	1/8"
Ch	13	13	13	13	13	13	13	13
Weight (Kg)	0,75	0,75	1	1	1,2	1,2	1,6	1,6
Air (dm ³ /cycle)	0,08	0,08	0,15	0,15	0,22	0,22	0,3	0,3

H = CENTER OF PLATE'S FIXING

dimensions

DATA SHEET from DAN106 (Nm) to DAN720 (Nm)							
Code	DAN0106411S	DAN0120411S	DAN0180411S	DAN0240411S	DAN0360411S	DAN0480411S	DAN0720411S
Spare seals	KGGI0060	KGGI0018	KGGI0019	KGGI0020	KGGI0021	KGGI0022	KGGI0023
Size	DAN106	DAN120	DAN180	DAN240	DAN360	DAN480	DAN720
ISO	F05/F07	F05/F07	F07/F10	F07/F10	F07/F10	F10/F12	F10/F12
A	237,1	257,4	289,9	313,6	339,3	387,7	433
B	17	17	22	22	22	27	27
C x depth	M6x9	M6x9	M8x12	M8x12	M8x12	M10x15	M10x15
D x depth	M8x12	M8x12	M10x15	M10x15	M10x15	M12x18	M12x18
E	50	50	70	70	70	102	102
F	70	70	102	102	102	125	125
G	13	13	16	17	19	19	19,5
H	42,8	44,8	54,5	58,1	60	57,4	61,5
I	12	12	15	15	19	19	22
L	103,3	107	137,5	141,1	148	164,9	178
M	44,8	46,8	56,5	60,1	62	72,9	78,5
N	58,5	60,2	81	81	86	92	99,5
O	19,3	19,3	24,8	24,8	24,3	29,5	29,5
P	38,5	40,2	51	51	56	62	69,5
Q	44,8	46,8	56,5	60,1	62	72,9	78,5
R	16,2	18	20,2	22,5	25,5	29	31,8
S	20	20	30	30	30	30	30
T	83,3	87	107,5	111,1	118	134,9	148
W (Gas)	1/8"	1/8"	1/8"	1/8"	1/8"	1/4"	1/4"
Ch	17	17	22	22	22	27	27
Weight (Kg)	2,5	2,6	4,6	5,4	6,5	9,6	12
Air (dm3/cycle)	0,55	0,59	0,95	1,3	1,8	2,6	3,5

H = CENTER OF PLATE'S FIXING

dimensions

DATA SHEET from DAN960 (Nm) to DAN1920 (Nm)						
Code	DAN0960411S	DAN0960412S	DAN1440412S	DAN1440411S	DAN1920412S	DAN1920411S
Spare seals	KGGI0024		KGGI0025		KGGI0026	
Size	DAN960		DAN1440		DAN1920	
ISO	F10/F12	F14	F12	F14	F12/F16	F14
A	479,4	479,4	567	567	601	601
B	36	36	36	36	46	46
C x depth	M10x15	M16x24	M12x18	M16x24	M12x18	M16x24
D x depth	M12x18	-	-	-	M20x30	-
E	102	140	125	140	125	140
F	125	-	-	-	165	-
G	19,5	19,5	19,5	19,5	18,5	18,5
H	78	78	86,5	86,5	99,2	99,2
I	24	24	27	27	32	32
L	198	198	216	216	237,7	237,7
M	93,5	93,5	101,5	101,5	114,7	114,7
N	104,5	104,5	114,5	114,5	123	123
O	38,5	38,5	38,5	38,5	48,5	48,5
P	74,5	74,5	84,5	84,5	93	93
Q	93,5	93,5	101,5	101,5	114,7	114,7
R	36,5	36,5	41	41	46	46
S	30	30	30	30	30	30
T	168	168	186	186	207,7	207,7
W (Gas)	1/4"	1/4"	1/4"	1/4"	1/4"	1/4"
Ch	27	27	36	36	36	36
Weight (Kg)	17,4	17,4	23,4	23,4	32	32
Air (dm ³ /cycle)	4,9	4,9	7,6	7,6	10,2	10,2

H = CENTER OF PLATE'S FIXING

dimensions

DA2880

Double acting pneumatic actuator size DA 2880 (Nm)

dimensions

DA5760

Double acting pneumatic actuator size DA 5760 (Nm)

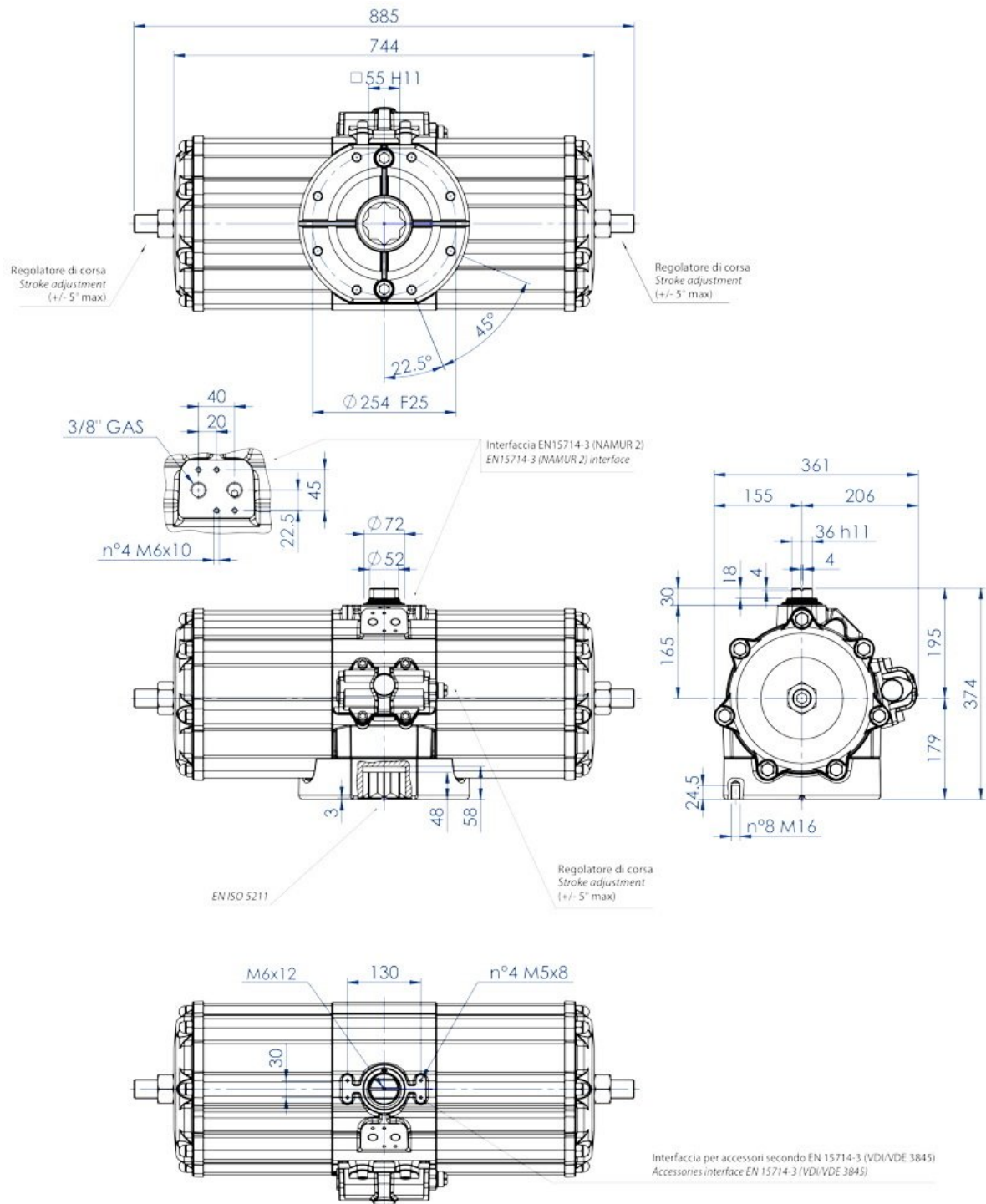

dimensions

DATA SHEET DA 5760 (Nm)	
Code	DA5760E25D0A
Weight [Kg]	85,5
Air volume [dm ³ /cycle]	38,0
Spare seals	KGDI2035

dimensions

DA8000

Double acting pneumatic actuator size DA 8000 (Nm)

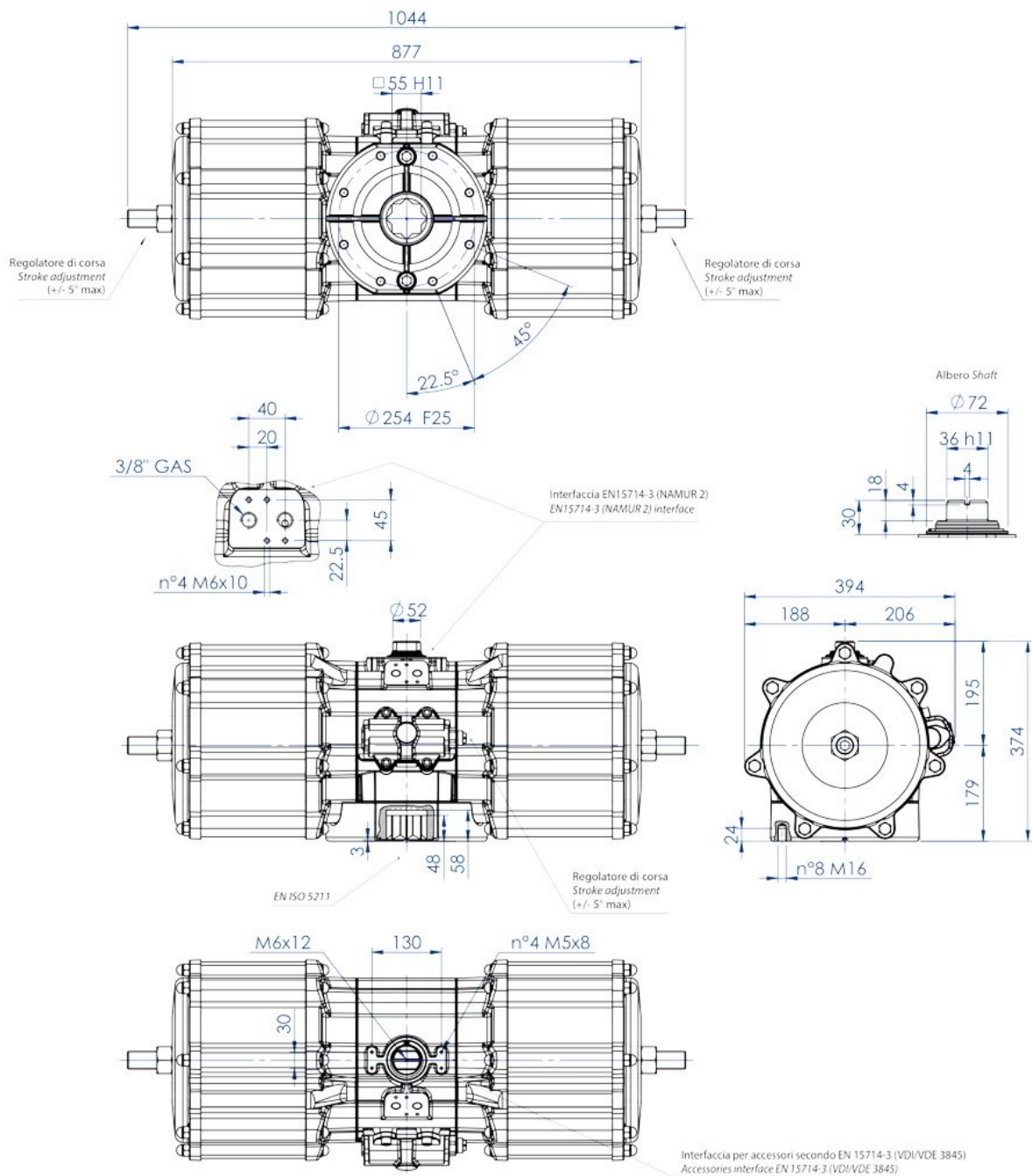

dimensions

DATA SHEET DA 8000 (Nm)	
Code	DA8000E25D0A
Weight [Kg]	105,5
Air volume [dm ³ /cycle]	50
Spare seals	KGD11040

materials

DA08

DOUBLE ACTING PNEUMATIC ACTUATOR COMPONENTS SIZES: DA8

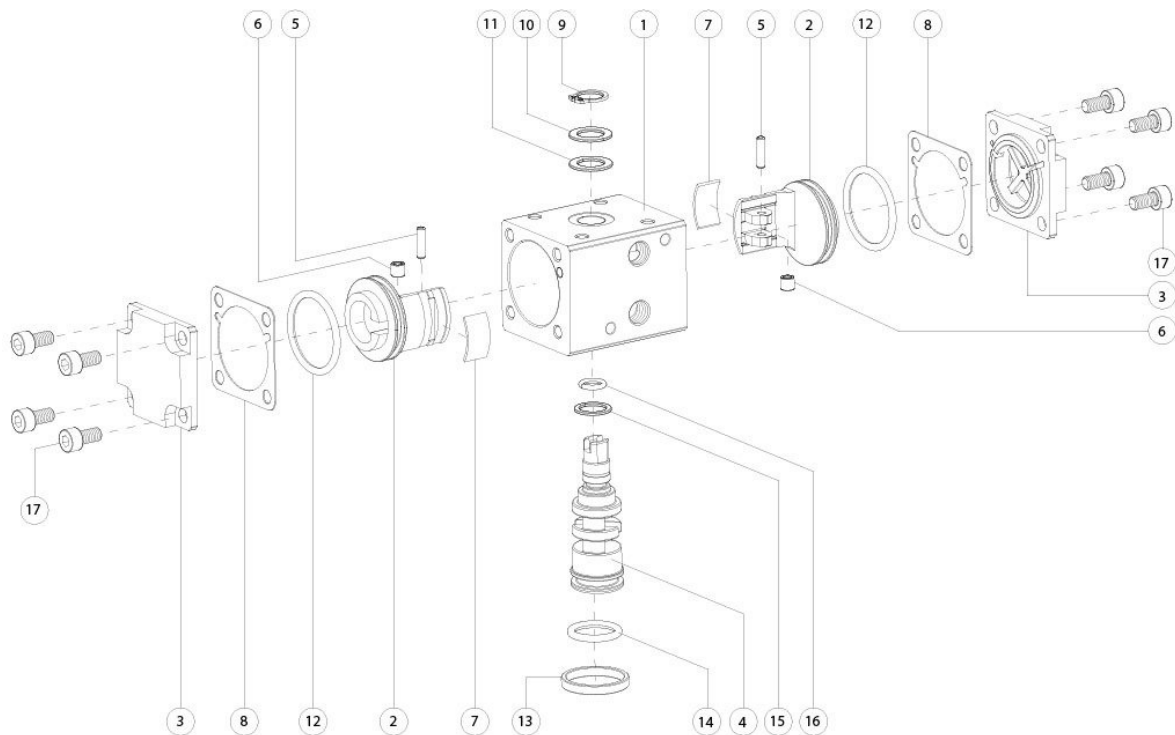

materials

DOUBLE ACTING PNEUMATIC ACTUATOR COMPONENTS SIZES: DA8			
Pos	Denomination	Q.ty	Material
1	Cylinder	1	Aluminium alloy
2	Piston	2	Aluminium alloy
3	Cap DA	2	Aluminium alloy
4	Shaft	1	Steel alloy
5	Sleeve	2	Steel alloy
6	Steel Bush	2	Steel alloy
7*	Support band	2	Acetalic resins
8*	O-ring	2	Nitrilic rubber
9	Seeger	1	Stainless steel
10	Washer	1	Stainless steel
11*	Ext. support ring	1	Acetalic resins
12*	O-ring	2	Nitrilic rubber
13	Center ring (OPTIONAL)	1	Aluminium alloy
14*	O-ring	1	FKM
15*	Int.support ring	1	Acetalic resins
16*	O-ring	1	FKM
17	Screw	8	Stainless steel

*Components of spare part kit

materials

DAN15 - DAN1920

DOUBLE ACTING PNEUMATIC ACTUATOR COMPONENTS SIZE: **DAN15-DAN1920**

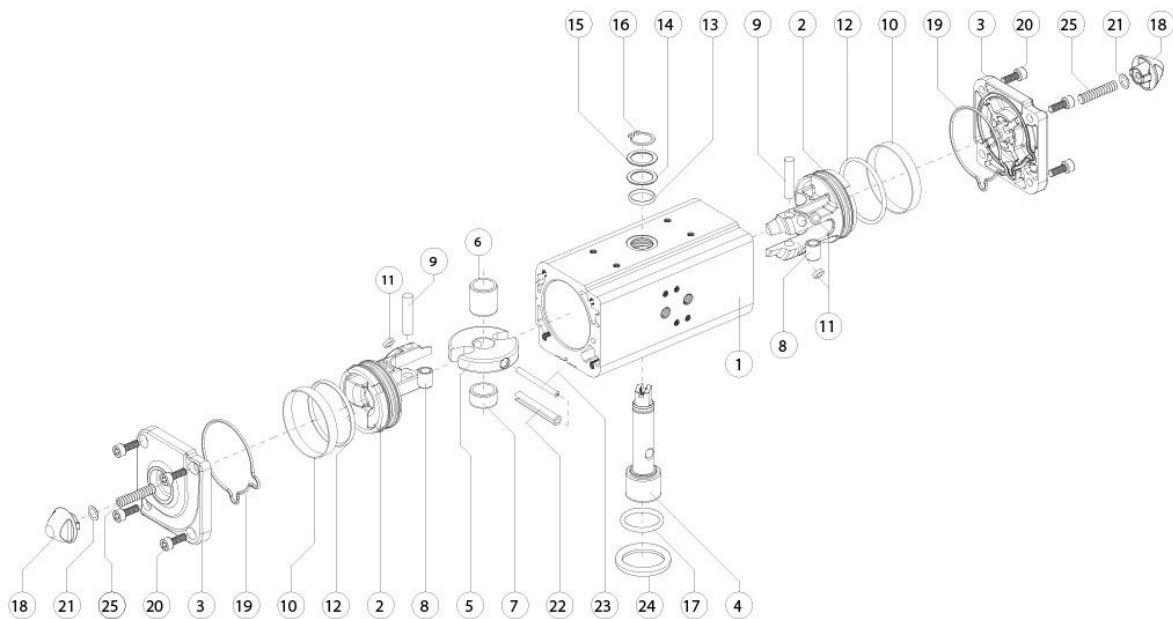

materials

DOUBLE ACTING PNEUMATIC ACTUATOR COMPONENTS SIZE: DAN15-DAN1920			
Pos	Denomination	Q.ty	Material
1	Cylinder	1	Aluminium alloy
2	Piston	2	Aluminium alloy
3	Cap	2	Aluminium alloy
4	Shaft	1	Stainless steel
5	Scotch yoke	1	Steel alloy
6	Support bush	1	Acetalic resin
7	Shaft support	1	Acetalic resin
8	Bush	2	Steel alloy
9	Rotative sleeve	2	Steel alloy
10*	Dynamic seal	2	Polyurethan
11*	Piston's suport	4	P.T.F.E. carbo-graphite filled
12*	O-ring	2	Nitrilic rubber
13	O-ring (upper sealing shaft)	1	FKM
14	External support ring	1	Acetalic resins
15	Washer	1	Stainless steel
16	Seeger	1	Stainless steel
17	O-ring (lower sealing shaft)	1	FKM
18	Nut	2	Aluminium alloy
19*	End-cap O-ring	2	Nitrilic rubber
20	Screws	8	Stainless steel
21*	O-ring	2	Nitrilic rubber
22	External elastic pin of the yoke	1	Steel alloy
23	Internal elastic pin of the yoke	1	Steel alloy
24	Centering ring (OPTIONAL)	1	Aluminium alloy
25	Stroke adjustment screw	2	Stainless steel
* Components of spare part kit			

materials

DA2880

DOUBLE ACTING PNEUMATIC ACTUATOR COMPONENTS SIZE: DA2880

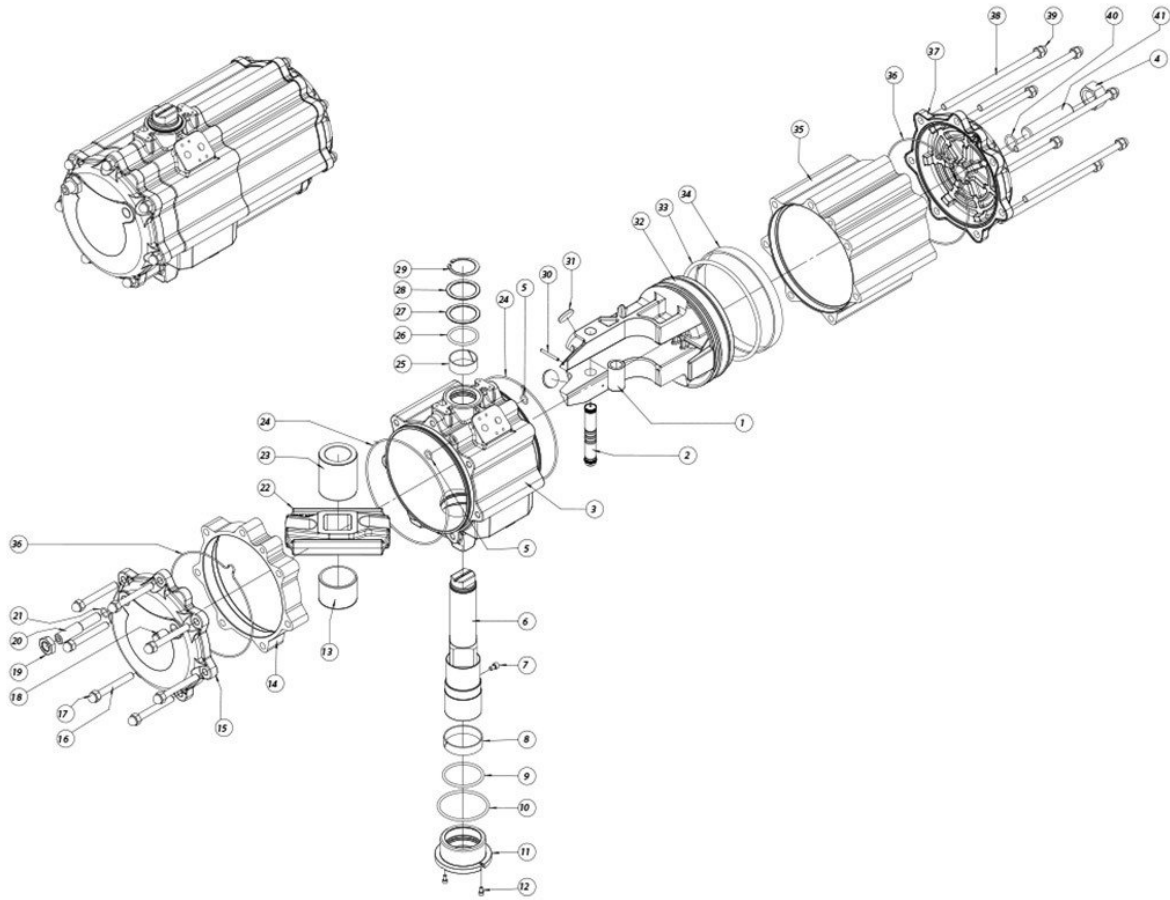

materials

DOUBLE ACTING PNEUMATIC ACTUATOR COMPONENTS SIZE: DA2880

Pos	Denomination	Q.ty	Material
1	Steel bush	1	Steel alloy
2	Steel pin	1	Steel alloy
3	Body	1	Aluminium
4	Nut	1	Steel alloy
5*	O-ring	2	Nitrilic rubber
6	Shaft	1	Steel alloy
7	Screw	1	Steel alloy
8*	Bearing (shaft bottom)	1	P.T.F.E. carbo-graphite filled
9*	O-ring	1	FKM
10*	O-ring	1	FKM
11	Low bearing bush	1	Aluminium
12	Screw	2	Steel alloy
13	Bearing shaft	1	Acetalic resin
14	Spacer	1	Aluminium
15	Cap	1	Aluminium
16	Cap screw	7	Steel alloy
17	Cap nut	7	Steel alloy
18	Grub screw	1	Steel alloy
19	Nut	1	Steel alloy
20	Grub screw	1	Steel alloy
21*	O-ring	1	Nitrilic rubber
22	Scotch yoke	1	Steel alloy
23	Bearing shaft	1	Acetalic resin
24*	O-ring	2	Nitrilic rubber
25*	Bearing (shaft top)	1	P.T.F.E. carbo-graphite filled
26*	O-ring	1	FKM
27*	Thrust bearing	1	Acetalic resin
28	Washer	1	Steel alloy
29	Seeger	1	Steel alloy
30	Spring pin	1	Steel alloy
31*	Bearing (piston back)	2	Acetalic resin
32	Piston	1	Aluminium
33*	O-ring	1	Nitrilic rubber
34*	Bearing (piston head)	1	P.T.F.E. Carbo-Graphite filled
35	Lateral cylinder	1	Aluminium
36*	O-ring	2	Nitrilic rubber
37	Cap	1	Aluminium
38	Cap screw	7	Steel alloy
39	Cap nut	7	Steel alloy
40*	O-ring	1	Nitrilic rubber
41	Grub screw	1	Steel alloy
*Components of spare part kit			

materials

DA3840

DOUBLE ACTING PNEUMATIC ACTUATOR COMPONENTS SIZE: DA3840

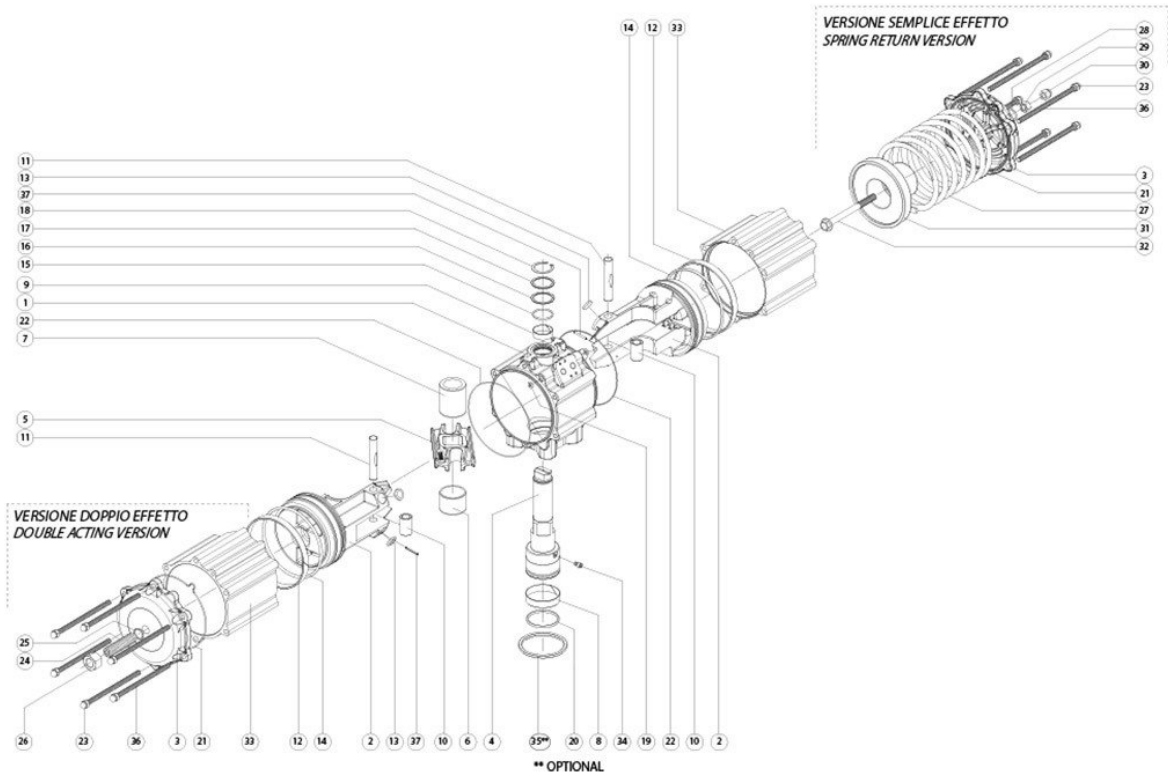

materials

DOUBLE ACTING PNEUMATIC ACTUATOR COMPONENTS SIZE: DA3840

Pos	Denomination	Q.ty	Material
1	Cylinder	1	Aluminium alloy
2	Piston	2	Aluminium alloy
3	Cap	2	Aluminium alloy
4	Shaft	1	Stainless steel
5	Scotch yoke	1	Steel alloy
6	Bearing shaft	1	Acetalic resins
7	Bearing shaft	1	Acetalic resins
8*	Bearing (shaft bottom)	1	P.T.F.E. carbo-graphite filled
9*	Bearing (shaft top)	1	P.T.F.E. carbo-graphite filled
10	Steel bush	2	Steel alloy
11	Steel pin	2	Steel alloy
12*	Bearing (piston head)	2	P.T.F.E. Carbo-Graphite filled
13*	Bearing (piston back)	4	Acetalic resins
14*	O-ring	2	Nitrilic rubber
15*	O-ring	1	FKM
16*	Thrust bearing	1	Acetalic resins
17	Washer	1	Stainless steel
18	Seeger	1	Stainless steel
19*	O-ring	2	Nitrilic rubber
20*	O-ring	1	FKM
21*	O-ring	2	Nitrilic rubber
22*	O-ring	2	Nitrilic rubber
23	Cap nut	12	Stainless steel
24	Grub screws	2	Stainless steel
25*	O-ring	2	Nitrilic rubber
26	Nut	2	Stainless steel
27	Spring	4	Steel alloy
28*	O-ring	2	Nitrilic rubber
29	Nut	2	Stainless steel
30	Cap nut	2	Stainless steel
31	Spring cap	2	Aluminium alloy
32	Screw	2	Stainless steel
33	Cylinder	2	Aluminium alloy
34	Screw	1	Stainless steel
35**	Center ring (OPTIONAL)	1	Aluminium alloy
36	Cap screw	12	Steel alloy
37	Spring pin	2	Steel alloy
*Components of spare part kit			
** Optional			

materials

DA5760

DOUBLE ACTING PNEUMATIC ACTUATOR COMPONENTS SIZE: DA5760

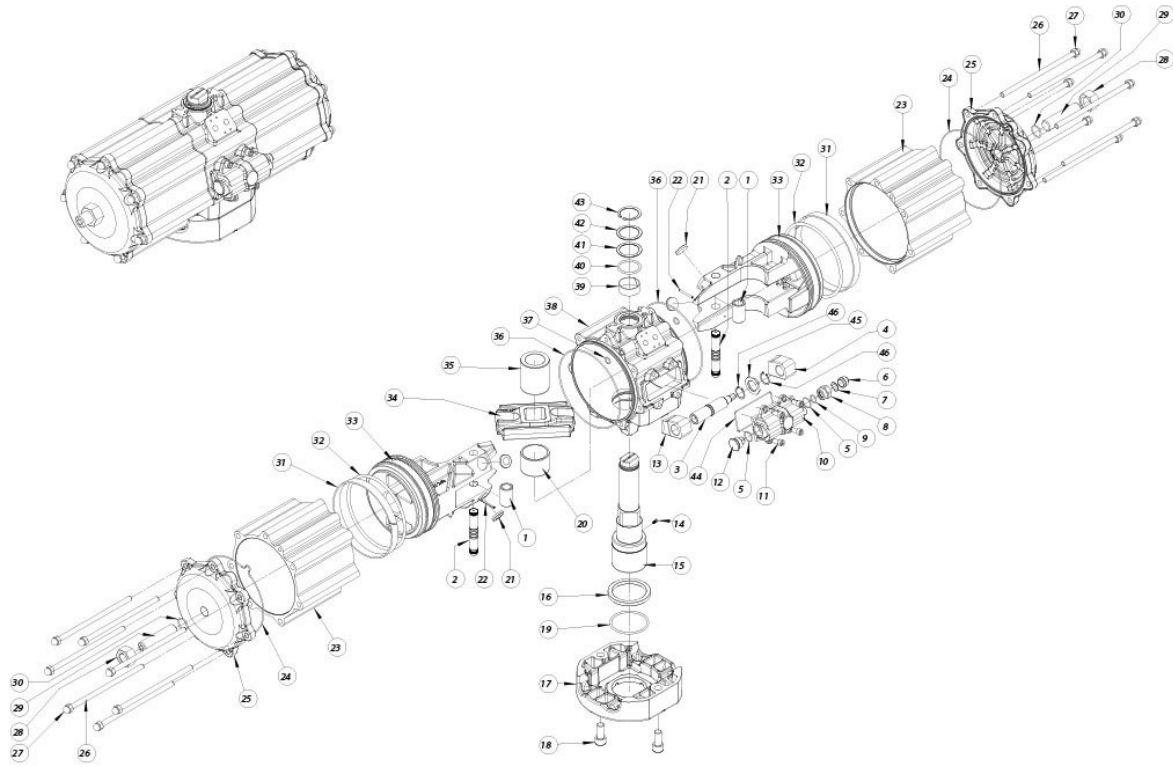

materials

DOUBLE ACTING PNEUMATIC ACTUATOR COMPONENTS SIZE: DA5760

Pos	Denomination	Q.ty	Material
1	Steel bush	2	Steel alloy
2	Steel pin	2	Steel alloy
3	Regolation screw	1	Steel alloy
4	Left stop	1	Steel alloy
5*	O-ring	2	Nitrilic rubber
6	Protection cap	1	Aluminium
7	Antirotation washer	1	Steel alloy
8	Metal ring	1	Stainless steel
9*	O-ring	1	Nitrilic rubber
10	Carter	1	Aluminium
11	Screw	4	Steel alloy
12	Metal ring	1	Stainless steel
13	Right stop	1	Steel alloy
14	Screw	1	Steel alloy
15	Shaft	1	Steel alloy
16	Bearing (shaft bottom)	1	P.T.F.E. carbo-graphite filled
17	Interface F25	1	Aluminium
18	Screw	2	Steel alloy
19*	O-ring	1	FKM
20	Bearing shaft	1	Acetalic resins
21*	Bearing (piston back)	4	Acetalic resins
22	Spring pin	2	Steel alloy
23	Lateral cylinder	2	Aluminium
24*	O-ring	2	Nitrilic rubber
25	Cap	2	Aluminium
26	Cap screws	14	Steel alloy
27	Cap nut	14	Steel alloy
28	Nut	2	Steel alloy
29	Grub screws	2	Steel alloy
30*	O-ring	2	Nitrilic rubber
31*	Bearing (piston head)	2	P.T.F.E. Carbo-Graphite filled
32*	O-ring	2	Nitrilic rubber
33	Piston	2	Aluminium
34	Scotch yoke	1	Steel alloy
35	Bearing shaft	1	Acetalic resin
36*	O-ring	2	Nitrilic rubber
37*	O-ring	2	Nitrilic rubber
38	Body	1	Aluminium
39*	Bearing (shaft top)	1	P.T.F.E. carbo-graphite filled
40*	O-ring	1	FKM
41*	Thrust bearing	1	Acetalic resin
42	Washer	1	Steel alloy
43	Seeger	1	Steel alloy
44*	Gasket	1	Nitrilic rubber
45	Washer	1	Steel alloy
46	Seeger	2	Steel alloy

*Components of spare part kit

materials

DA8000

DOUBLE ACTING PNEUMATIC ACTUATOR COMPONENTS SIZE: DA8000

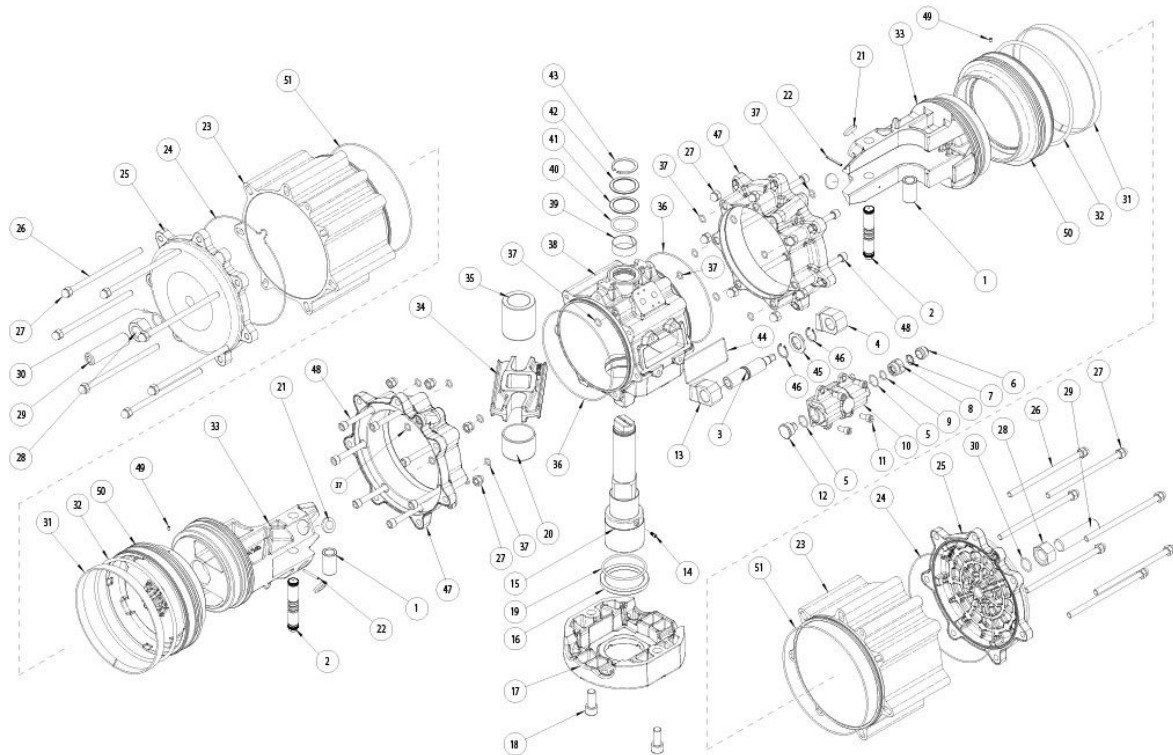

materials

DOUBLE ACTING PNEUMATIC ACTUATOR COMPONENTS SIZE: DA8000

Pos	Denomination	Q.ty	Material
1	Steel bush	2	Steel alloy
2	Steel pin	2	Steel alloy
3	Regulation screw	1	Steel alloy
4	Left stop	1	Steel alloy
5*	O-ring	2	Nitrilic rubber
6	Protection cap	1	Aluminium
7	Antirotation washer	1	Steel alloy
8	Metal ring	1	Stainless steel
9*	O-ring	1	Nitrilic rubber
10	Carter	1	Aluminium
11	Screw	4	Steel alloy
12	Metal ring	1	Stainless steel
13	Right stop	1	Steel alloy
14	Screw	1	Steel alloy
15	Shaft	1	Steel alloy
16	Bearing (shaft bottom)	1	P.T.F.E. carbo-graphite filled
17	Interface F25	1	Aluminium
18	Screw	2	Steel alloy
19*	O-ring	1	FKM
20	Bearing shaft	1	Acetalic resins
21*	Bearing (piston back)	4	Acetalic resins

22	Spring pin	2	Steel alloy
23	Lateral cylinder	2	Aluminium
24*	O-ring	2	Nitrilic rubber
25	Cap	2	Aluminium
26	Cap screws	14	Steel alloy
27	Cap nut	28	Steel alloy
28	Nut	2	Steel alloy
29	Grub screws	2	Steel alloy
30*	O-ring	2	Nitrilic rubber
31*	Bearing (piston head)	2	P.T.F.E. Carbo-Graphite filled
32*	O-ring	2	Nitrilic rubber
33	Piston	2	Aluminium
34	Scotch yoke	1	Steel alloy
35	Bearing shaft	1	Acetalic resins
36*	O-ring	2	Nitrilic rubber
37*	O-ring	18	Nitrilic rubber
38	Body	1	Aluminium
39*	Bearing (shaft top)	1	P.T.F.E. carbo-graphite filled
40*	O-ring	1	FKM
41*	Thrust bearing	1	Acetalic resins
42	Washer	1	Steel alloy
43	Seeger	1	Steel alloy
44*	Gasket	1	Nitrilic rubber
45	Washer	1	Steel alloy
46	Seeger	2	Steel alloy
47	Flange	2	Aluminium
48	Screws	14	Steel alloy
49	Screw	2	Steel alloy
50	Flange	2	Aluminium
51*	O-ring	2	Nitrilic rubber

* Components of spare part kit

diagrams and breakaway torque

Output torque diagram related to rotation angle

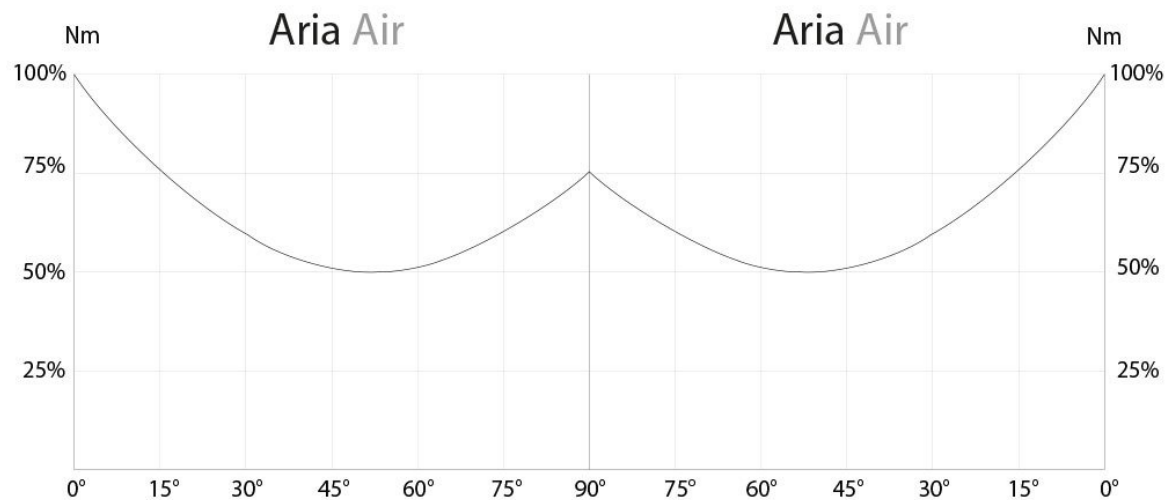

OUTPUT TORQUE TABLE (Nm) α°= ROTATION ANGLE								
SIZE	α°	3 bar	4 bar	5 bar	5,6 bar	6 bar	7 bar	8 bar
DA 08	0°	3,8	5	6,3	7	7,5	8,8	10
	45°	1,9	2,5	3,1	3,5	3,8	4,4	5
	90°	3,8	5	6,3	7	7,5	8,8	10
DAN 15	0°	8,0	10,7	13,4	15,0	16,1	18,8	21,4
	50°	4,0	5,4	6,7	7,5	8,0	9,4	10,7
	90°	6,1	8,1	10,1	11,3	12,1	14,1	16,1
DAN 30	0°	16,1	21,4	26,8	30,0	32,1	37,5	42,9
	50°	8,0	10,7	13,4	15,0	16,1	18,8	21,4
	90°	12,1	16,1	20,1	22,5	24,1	28,1	32,1
DAN 45	0°	24,1	32,1	40,2	45,0	48,2	56,3	64,3
	50°	12,1	16,1	20,1	22,5	24,1	28,1	32,1
	90°	18,1	24,1	30,1	33,8	36,2	42,2	48,2
DAN 60	0°	32,1	42,9	53,6	60,0	64,3	75,0	85,7
	50°	16,1	21,4	26,8	30,0	32,1	37,5	42,9
	90°	24,1	32,1	40,2	45,0	48,2	56,3	64,3
DAN 106	0°	56,8	75,7	94,6	106,0	113,6	132,5	151,4
	50°	28,4	37,9	47,3	53,0	56,8	66,3	75,7
	90°	42,9	57,1	71,4	80,0	85,7	100,0	114,3
DAN 120	0°	64,3	85,7	107,1	120,0	128,6	150,0	171,4
	50°	32,1	42,9	53,6	60,0	64,3	75,0	85,7
	90°	48,2	64,3	80,4	90,0	96,4	112,5	128,6
DAN 180	0°	96,4	128,4	160,7	180,0	192,9	225,0	257,1
	50°	48,2	64,3	80,4	90,0	96,4	112,5	128,6
	90°	72,3	96,4	120,5	135,0	144,6	168,8	192,9
DAN 240	0°	128,6	171,4	214,3	240,0	257,1	300,0	342,9
	50°	64,3	85,7	107,1	120,0	128,6	150,0	171,4
	90°	96,4	128,6	160,7	180,0	192,9	225,0	257,1
DAN 360	0°	192,9	257,1	321,4	360,0	385,7	450,0	514,3
	50°	96,4	128,6	160,7	180,0	192,9	225,0	257,1
	90°	144,6	192,9	241,1	270,0	289,3	337,5	385,7
DAN 480	0°	257,1	342,9	428,6	480,0	514,3	600,0	685,7
	50°	128,6	171,4	214,3	240,0	257,1	300,0	342,9
	90°	192,9	257,1	321,4	360,0	385,7	450,0	514,3
DAN 720	0°	385,7	514,3	642,9	720,0	771,4	900,0	1028,6
	50°	192,9	257,1	321,4	360,0	385,7	450,0	514,3
	90°	289,3	385,7	482,1	540,0	578,6	675,0	771,4
DAN 960	0°	514,3	685,7	857,1	960,0	1028,6	1200,0	1371,4
	50°	257,1	342,9	428,6	480,0	514,3	600,0	685,7
	90°	385,7	514,3	642,9	720,0	771,4	900,0	1028,6
DAN 1440	0°	771,4	1028,6	1285,7	1440,0	1542,9	1800,0	2057,1
	50°	385,7	514,3	642,9	720,0	771,4	900,0	1028,6
	90°	578,6	771,4	964,3	1080,0	1157,1	1350,0	1542,9
DAN 1920	0°	1028,6	1371,4	1714,3	1920,0	2057,1	2400,0	2742,9
	50°	514,3	685,7	857,1	960,0	1028,6	1200,0	1371,4
	90°	771,4	1028,6	1285,7	1440,0	1542,9	1800,0	2057,1
DA 2880	0°	1542,9	2057,1	2571,4	2880,0	3085,7	3600,0	4114,3
	50°	771,4	1028,6	1285,7	1440,0	1542,9	1800,0	2057,1
	90°	1157,1	1542,9	1928,6	2160,0	2314,3	2700,0	3085,7
DA 3840	0°	2057,1	2742,9	3428,6	3840,0	4114,3	4800,0	5485,7
	50°	1028,6	1371,4	1714,3	1920,0	2057,1	2400,0	2742,9
	90°	1542,9	2057,1	2571,4	2880,0	3085,7	3600,0	4114,3
DA 5760	0°	3085,7	4114,3	5142,9	5760,0	6171,4	7200,0	8228,6
	50°	1542,9	2057,1	2571,4	2880,0	3085,7	3600,0	4114,3
	90°	2314,3	3085,7	3857,1	4320,0	4628,6	5400,0	6171,4
DA 8000	0°	4285,7	5714,3	7142,9	8000,0	8571,4	10000,0	---
	50°	2142,9	2857,1	3571,4	4000,0	4285,7	5000,0	---
	90°	3214,3	4285,7	5357,1	6000,0	6428,6	7500,0	---

specifications

WORKING PLANE PNEUMATIC ACTUATOR "DA" TYPE

SCHEMA FUNZIONAMENTO ATTUATORE PNEUMATICO AGO "DA" WORKING PLANE PNEUMATIC ACTUATOR AGO "DA" TYPE

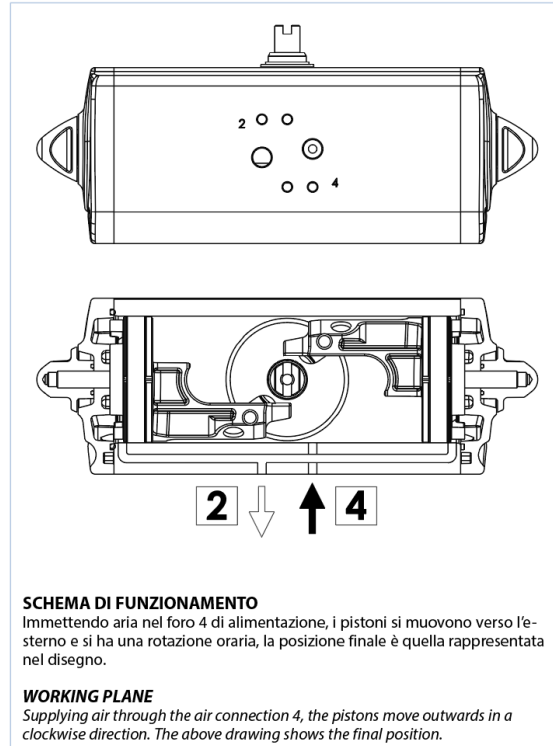
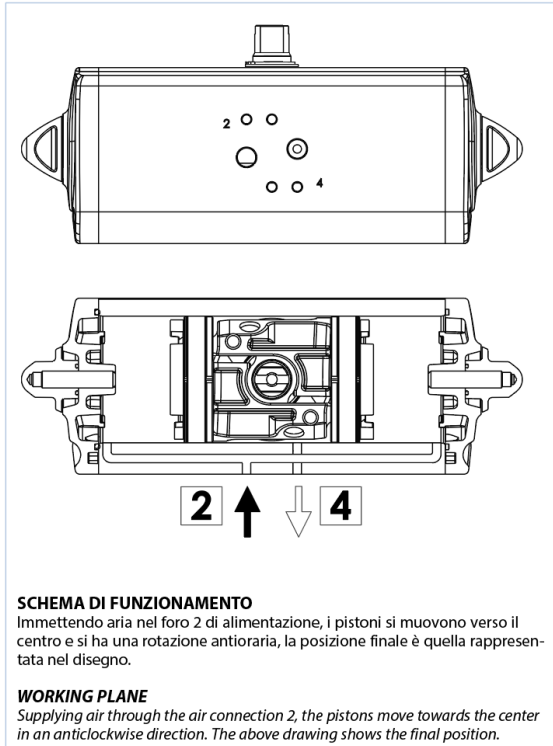

ATTUATORE REGOLABILE-ISTRUZIONI PER L' UTILIZZO ACTUATOR WITH STROKE ADJUSTMENT-INSTRUCTIONS

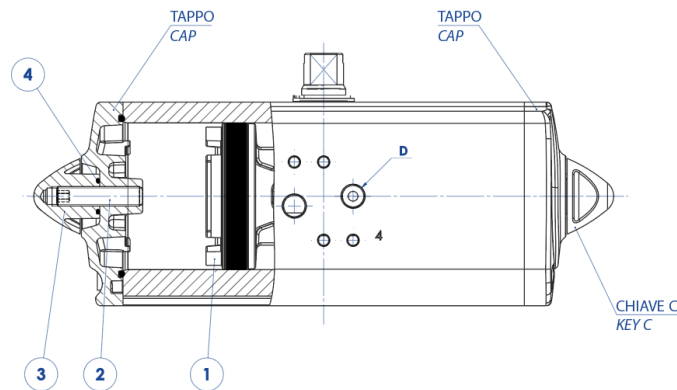

- A)** Immettere aria nel foro "D" in modo che i pistoni (part. n°1) si vengano a trovare in posizione di finecorsa verso i tappi.
B) Togliere il controdado (part. n°3) agendo sulla chiave C.
C) Togliere l'aria di alimentazione.
D) Con una chiave a brugola agire sulle viti (part. n°2) ed effettuare la limitazione di corsa desiderata.
N.B. La corsa può essere limitata per un massimo di 10° da 80° a 90°. Altre regolazioni disponibili a richiesta.
E) Mettere aria nel foro "D"; verificare che entrambe le viti (part. n°2) siano a battuta contro i pistoni.
F) Mettere il controdado (part. n°3) munito di O-ring (part. n°4) per la tenuta tra dado e tappo.
- N.B. queste spiegazioni sono indicative, per le istruzioni operative, vedere il manuale.

- A)** Supply air through the air connection D so that the pistons (Part. 1) move to the end-stroke position, towards the caps.
B) Remove the counter nut (part. 3) acting on the C key.
C) Shut off the air supply.
D) Adjust the end stroke as desired, acting on the screws (part 2) with an hexagonal key.
Note: maximum adjusting stroke 10°, ranging from 80° to 90°. Other regulations on request.
E) Supply air through the air connection D and check that both screws stop the pistons.
F) Screw the counter-nut (part 3) and its o-ring (part 4) to keep nut and cap tight.
- N.B. these explanations are indicative, for operating instructions, see the manual.

accessories

LIMIT SWITCH BOX

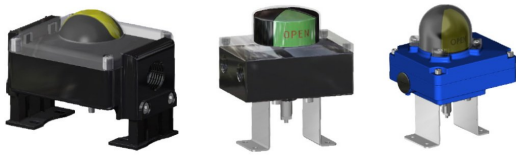

MANUAL OVERRIDE WITH HAND WHEEL



NAMUR SOLENOID VALVES



SOLENOID VALVES



ELECTROPNEUMATIC POSITIONER (INTRINSICALLY SAFE)

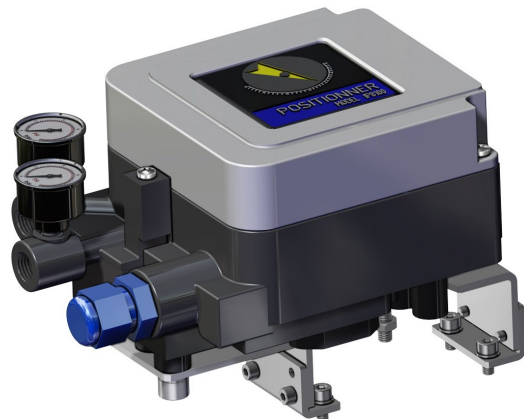

PNEUMATIC POSITIONER

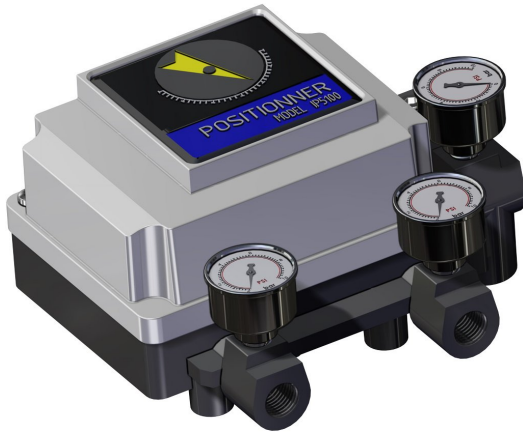

PROXIMITY LIMIT SWITCHES

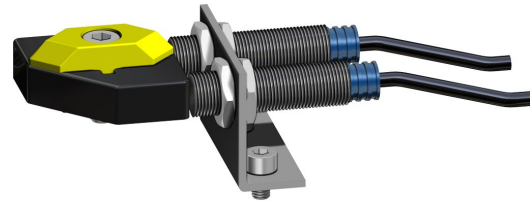

ELECTROMECHANICAL LIMIT SWITCHES

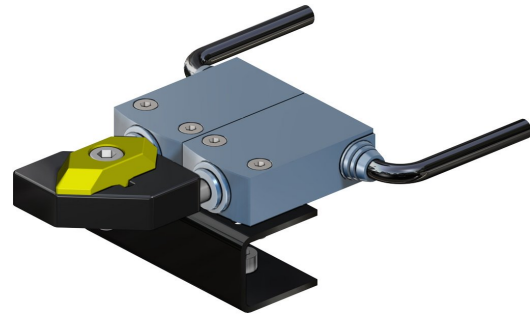

PNEUMATIC LIMIT SWITCHES

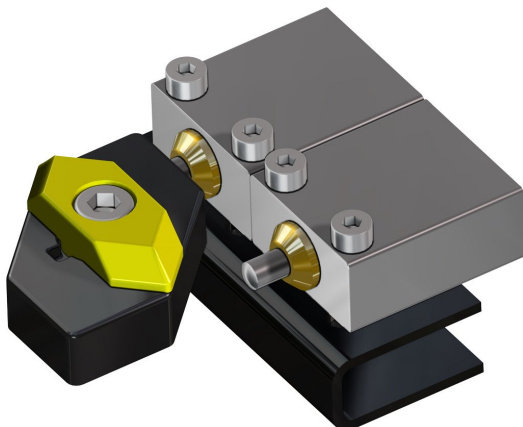

EXPLOSION PROOF LIMIT SWITCHES IIC2GD ExdIIC

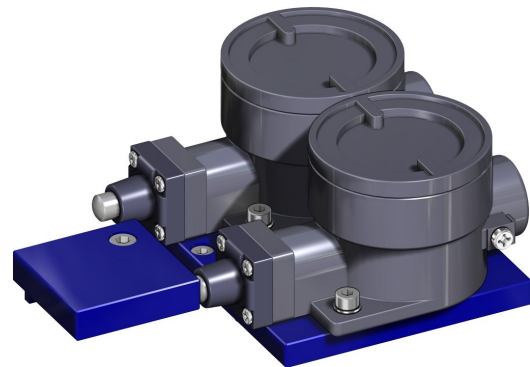

documents

Instructions

[ATEX MANUAL UITGOG01ATX](#)
[USER MANUAL UITGOG01](#)

Manuals

1. [MANUAL DA8 - UMA800081A](#)
1. [MANUAL DAN15-DAN1920 SRN15-SRN960 - UMAAPG00](#)
2. [MANUAL DA2880-DA8000 SR1440-SR4000 - UMA800081C](#)

Certificates

[ATEX - Pneumatic Actuators](#)
[SIL EN 61508 - Actuators: SR, SRN, DA, DAN](#)
[Type Approval Certificate for Marine and machinery systems and equipment](#)