



Warning: filectime(): stat failed for /var/www/vhost/www.omal.it/htdocs/https://www.omal.it./FilesProdotti/TA-LUFT.pdf in /var/www/vhost/www.omal.it/htdocs/prodotto-printable.php on line 65

Warning: filectime(): stat failed for /var/www/vhost/www.omal.it/htdocs/https://www.omal.it./FilesProdotti/RICEVUTADEPOSITOF.T.ATEXN.VS-19.pdf in /var/www/vhost/www.omal.it/htdocs/prodotto-printable.php on line 65

Warning: filectime(): stat failed for /var/www/vhost/www.omal.it/htdocs/https://www.omal.it./FilesProdotti/Certificate-202053402-OMAL-ValvoleMagnum-Thor-new.pdf in /var/www/vhost/www.omal.it/htdocs/prodotto-printable.php on line 65

Warning: filectime(): stat failed for /var/www/vhost/www.omal.it/htdocs/https://www.omal.it./FilesProdotti/FG-063579-645FUGITIVEEMISSIONDN25CL.300TI-T2-T3-M1-M4-M5-M6.pdf in /var/www/vhost/www.omal.it/htdocs/prodotto-printable.php on line 65

Warning: filectime(): stat failed for /var/www/vhost/www.omal.it/htdocs/https://www.omal.it./FilesProdotti/FG-063579-646FUGITIVEEMISSIONDN100CL.300THORTI-T2-T3-M1-M4-M5-M6.pdf in /var/www/vhost/www.omal.it/htdocs/prodotto-printable.php on line 65

Warning: filectime(): stat failed for /var/www/vhost/www.omal.it/htdocs/https://www.omal.it./FilesProdotti/Cert.C539822.pdf in /var/www/vhost/www.omal.it/htdocs/prodotto-printable.php on line 65

Warning: filectime(): stat failed for /var/www/vhost/www.omal.it/htdocs/https://www.omal.it./FilesProdotti/UMAH1000-IT-01-21.pdf in /var/www/vhost/www.omal.it/htdocs/prodotto-printable.php on line 65

Warning: filectime(): stat failed for /var/www/vhost/www.omal.it/htdocs/https://www.omal.it./FilesProdotti/80844-37-ValvoleasferaThorSplitBody3VieT2-T3-IT-EN-0522.pdf in /var/www/vhost/www.omal.it/htdocs/prodotto-printable.php on line 65

Warning: filectime(): stat failed for /var/www/vhost/www.omal.it/htdocs/https://www.omal.it./FilesProdotti/UKCA-PER-H.pdf in /var/www/vhost/www.omal.it/htdocs/prodotto-printable.php on line 65

THOR Split Body 3 ways 4 seals PN 16-40 ANSI 150 carbon steel ball valve



Macro Ball valves

Category THOR

Subcategory THOR Split Body 3 ways 4 seals

Family THOR Split Body 3 ways 4 seals PN 16-40 ANSI 150

benefits

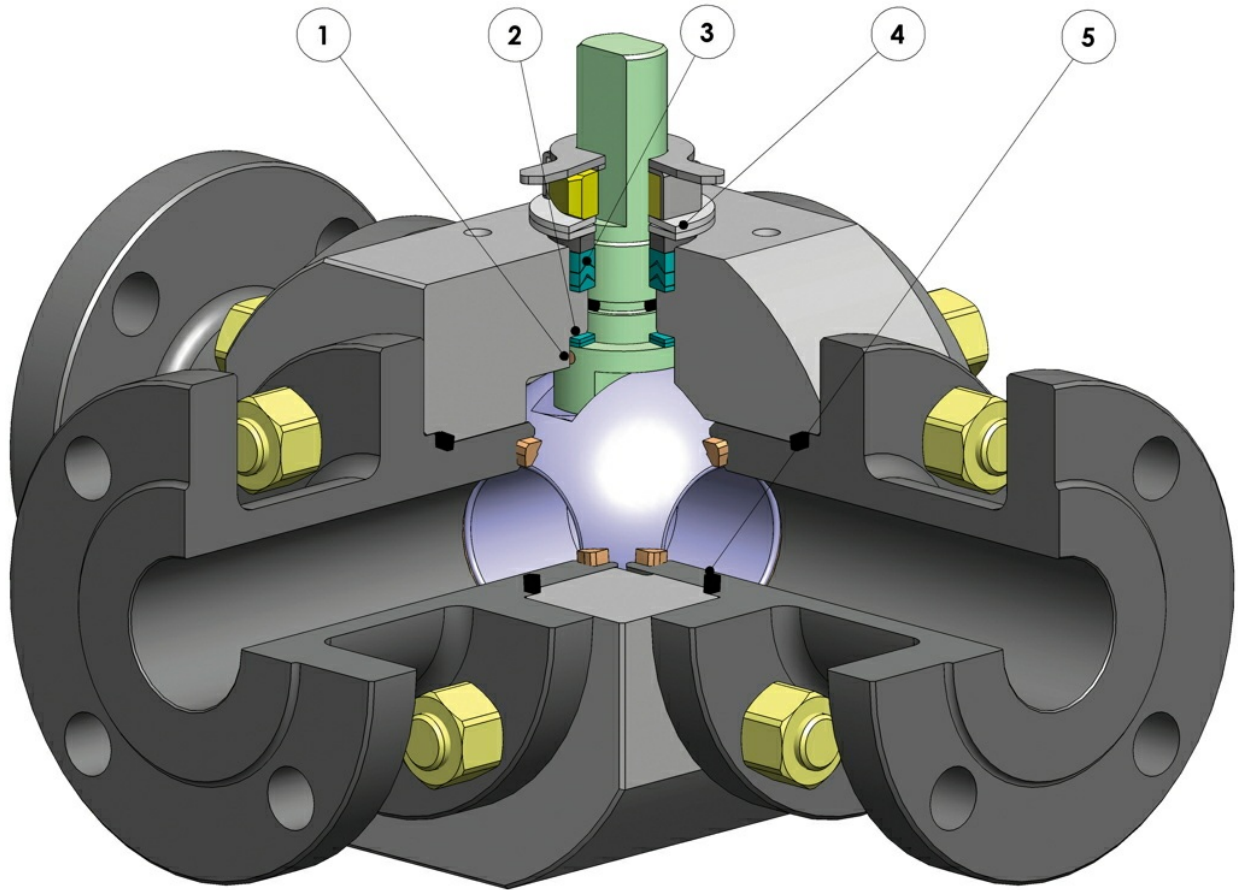



1. Antistatic device ((electrical continuity between ball, stem and body)

Static electricity is avoided which can cause sparks and fire in an inflammable/explosive environment

Contact safety throughout the entire life of the valve

2. Double antifriction washer

Less Breakaway Torque is granted

Less wear comparing with the execution with the single washer

3. "V" seals pack; 3 seals + o-ring

It ensures a perfect tightness even after a high number of cycles

4. Spring washer on the shaft seal

Guarantee of the recovery of the gap due to the wear caused by the rotational movement of the shaft avoiding leakage towards the outside part.

Allow to maintain energized the "chevron" seals (V), thus avoiding any leakage to the outside, against huge temperature excursions

5. Stretch Graphite seal

Tightness towards outside is granted, independently by the thermal excursions to which the valve is subjected

Greater precision in the alignment of axes due to a unique positioning in the process machining from raw material to finished valve

Less breakaway torque

Longer lifetime of the valve

Easy maintainance directly on site

Reduced maintainance costs

Valve body in carbon steel made with NACE certified material as standard

Greater corrosion resistance

Greater ductility of the material

100% in- house manufacturing process technology

Maximum control and accuracy in all the stages of the manufacturing process

Flexibility in supply quickly special executions requested by customers

ATEX Certificate

Installation is possible in a potential explosive environment

TA LUFT fugitive emission Certificate

High level of safety of the tightness towards the outside is granted

PED Certificate

Full compliance with European Safety Standards for Pressure Equipment





features

STANDARD EXECUTIONS

- Floating ball, full bore
- Soft-seat seal TFM 1600
- Standard for connecting flanges: EN1092-1, ASME B16.5
- Pressure Class : ansi 150; PN16-40
- Tightness Class: EN12266-1 rate A
- Working temperature: -20°C +150°C
- Intercepted fluid: air, water, gas, petroleum and petrochemical products, aggressive fluids.
- Antistatic device EN12266-2
- Stem seal: Modified PTFE V-pack
- Additional seal on stem with FKM O-ring
- Anti Blow-out stem
- Actuator connection as per standard ISO 5211

EXECUTIONS ON REQUEST

- LF2 carbon steel for low temperature execution (-40°C)
- For other flange types please contact our sales department.
- Sealing in: PTFE reinforced with glass (PTFE-GF), PTFE reinforced with carbongraphite (PTFE-CF). For other types of materials please contact our sales department.
- Stainless steel lever
- Stainless steel stem nuts and springs
- For special versions with materials (body/ball/stem) different from the standard please contact our sales department
- Surface treatment: white zinc coating, epoxy coating. For other coating please contact our sales department.
- ATEX marking and certificate ON REQUEST

CERTIFICATIONS

- In compliance with European Directive 2014/68/EU PED; Fugitive Emission ISO 15848 (ISO FE BH-C03-SSA 0); Ta-Luft VDI: 2440
- Safety integrity level up to SIL3 according to the IEC 61508
- In compliance with ATEX 2014/34/EU Directive , ATEX certificate ON REQUEST.

ENGINEERING STANDARDS

- Body thickness in compliance with: ASME B16.34, ASME VIII div.1, EN12516
- Materials and rating in compliance with ASME B16.34 for ANSI valves and EN12516 for PN valves.



dimensions

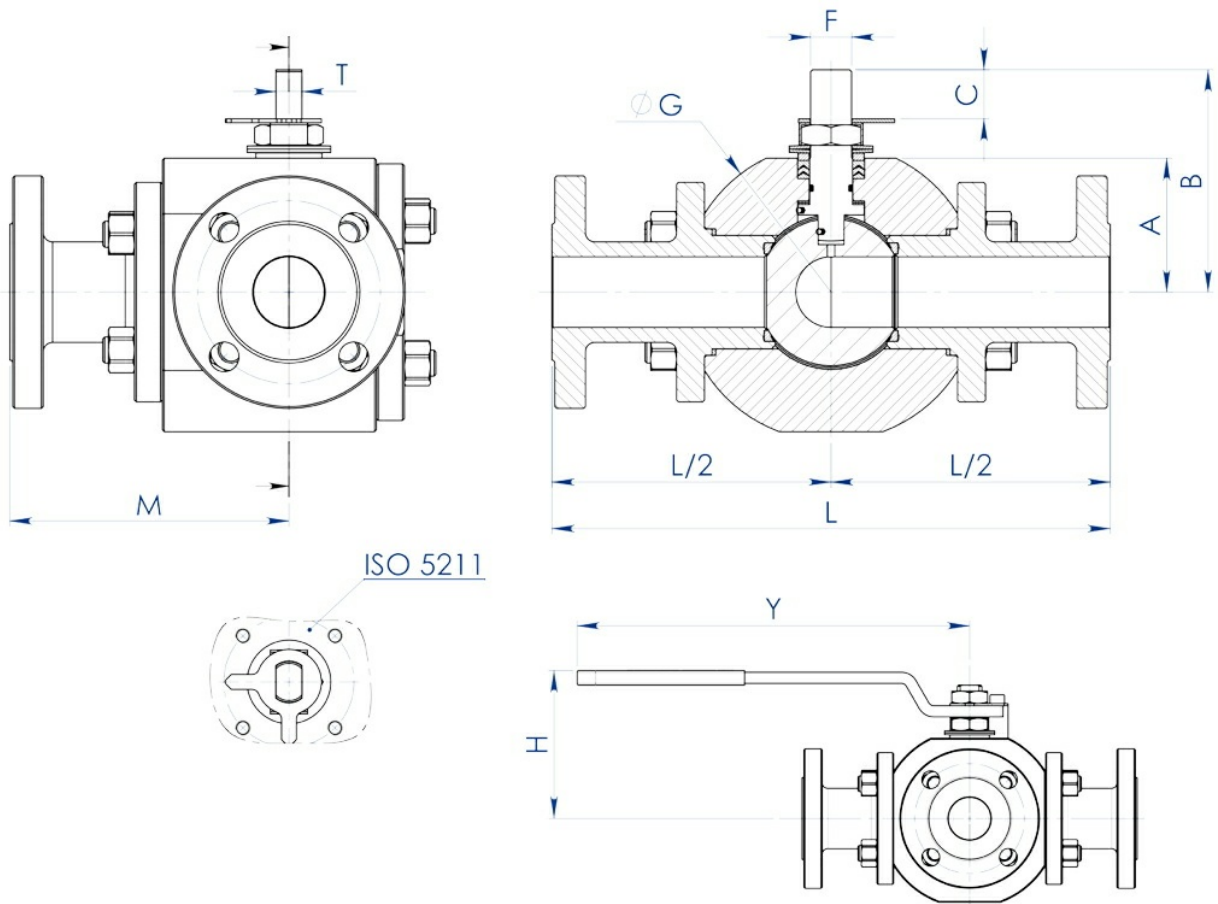



DIMENSIONS -PN-

SIZE		PN	øE	L	M	A	B	C	ATT. ISO	F/T	øG	øJ	øRS	P	øK	HOLES N°	øI	H	Y	Kg	LEVER KIT
DN [mm]	[inch]																				
DN 15	1/2"	16-40	13	170	85	35	55	9,2	F03	10/6	84	95	45	216	65	4	14	74	140	5,8	KLV58004
DN 20	3/4"	16-40	19	200	100	45	71	13	F04	12/8	105	105	58	218	75	4	14	90,5	150	10,2	KLV58006
DN 25	1"	16-40	25	230	115	55,5	90,5	19,1	F05	16/10	128	115	68	218	85	4	14	107	275	16,4	KLV58008
DN 32	1" 1/4	16-40	32	240	120	60	95	19,1	F05	16/10	135	140	78	218	100	4	18	111,3	275	19,1	KLV58008
DN 40	1" 1/2	16-40	38	300	150	72	119,5	26,4	F07	22/14	160	150	88	318	110	4	18	134,5	350	27,6	KLV58010
DN 50	2"	16-40	51	320	160	81	128,5	26,4	F07	22/14	178	165	102	320	125	4	18	143,5	350	39,2	KLV58010
DN 65	2" 1/2	16	64	350	175	93	154	33,1	F10	30/18	205	185	122	318	145	4	18	182,3	450	57,3	KLV58012
DN 80	3"	16	76	370	185	101	162	33,1	F10	30/18	220	200	138	324	160	8	18	190,3	450	71,2	KLV58012
DN 100	4"	16	102	400	200	124	182	33,1	F10	30/18	270	220	158	320	180	8	18	210,5	450	100,2	KLV58012

DIMENSIONS -ANSI-

SIZE		ANSI	øE	L	M	A	B	C	ATT. ISO	F/T	øG	øJ	øR	S	P	øK	HOLES N°	øI	H	Y	Kg	
DN [mm]	[inch]																					
DN 15	1/2"	150	13	170	85	35	55	9,2	F03	10/6	84	90	35,1	1,6	11,6	60,5	4	16	74	140	4,9	KL
DN 20	3/4"	150	19	200	100	45	71	13	F04	12/8	105	100	42,9	1,6	13,2	69,8	4	16	90,5	150	9,1	KL
DN 25	1"	150	25	230	115	55,5	90,5	19,1	F05	16/10	128	110	50,8	1,6	15,0	79,2	4	16	107	275	15,6	KL
DN 32	1" 1/4	150	32	240	120	60	95	19,1	F05	16/10	135	118	63,5	1,6	16,1	88,9	4	16	111,3	275	16,7	KL
DN 40	1" 1/2	150	38	300	150	72	119,5	26,4	F07	22/14	160	128	73	1,6	18,0	98,6	4	16	134,5	350	25,8	K
DN 50	2"	150	51	320	160	81	128,5	26,4	F07	22/14	178	153	91,9	1,6	20,0	120,6	4	19	143,5	350	37,7	K
DN 65	2" 1/2	150	64	350	175	93	154	33,1	F10	30/18	205	180	104,6	1,6	23,0	139,7	4	19	182,3	450	59,1	K
DN 80	3"	150	76	370	185	101	162	33,1	F10	30/18	220	190	127	1,6	24,6	152,4	4	19	190,3	450	70,6	K
DN 100	4"	150	102	400	200	124	182	33,1	F10	30/18	270	230	157,2	1,6	24,5	190,5	8	19	210,5	450	105,1	K

Note: for valves with T port, type dimensions do not change.



materials

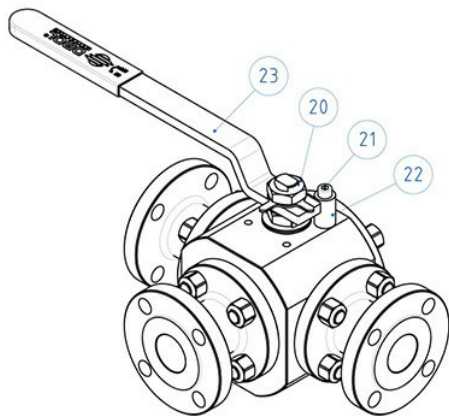
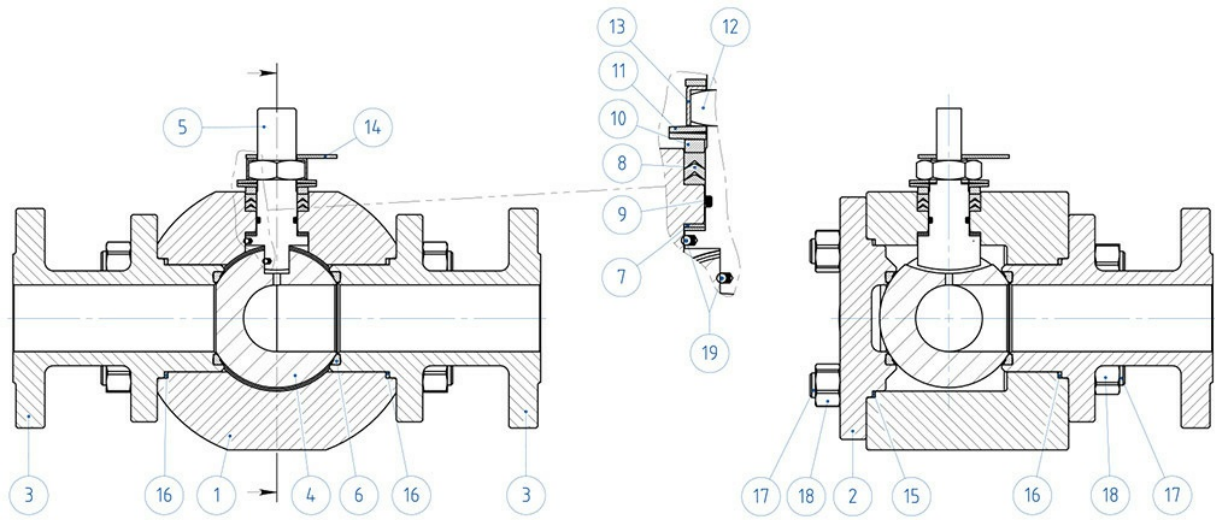



MATERIALS			
SPLIT BODY PN16-40 ANSI 150			
N°	Description	A350 LF2 Carbon steel	A105 Carbon steel
1	Body	ASTM A350 LF2	ASTM A105
2	Cover		
3	Connector		
4	Ball	ASTM A351 CF8M	
5	Stem	A564 TP.630 (17-4PH)	
6*	Seat	Modified PTFE	
7*	Stem lower sealing	Modified PTFE	
8*	Chevron rings	Modified PTFE	
9*	Stem O-ring	FKM	
10	Packing gland ring	Carbon steel galvanized (x)	
11	Stem springs	Carbon steel galvanized (xx)	
12	Stem nut	Carbon steel galvanized (x)	
13	Stop nut plate	304 S.S.	
14	Indicator	304 S.S.	
15*	Body-Cover nut gasket	Grafoil	
16*	Body-Connector gasket	Grafoil	
17	Stud bolt	ASTM A320 L7M	ASTM A193-B7
18	Nut	ASTM A194-Gr.7M	ASTM A194-Gr.2H
19	Antistatic device	316 S.S.	
20	Lock nut	Carbon steel galvanized (x)	
21	Holder screw	A2-70 (304 S.S.)	
22	Holder screw	Carbon steel galvanized (x)	
23	Lever	Fe37 galvanized (x)	
* Components of seals kit			

Available on request:

(x): 304 s.s.

(xx): 301 s.s.



diagrams and breakaway torque

Flow/pressure loss diagram and Kv nominal coefficient

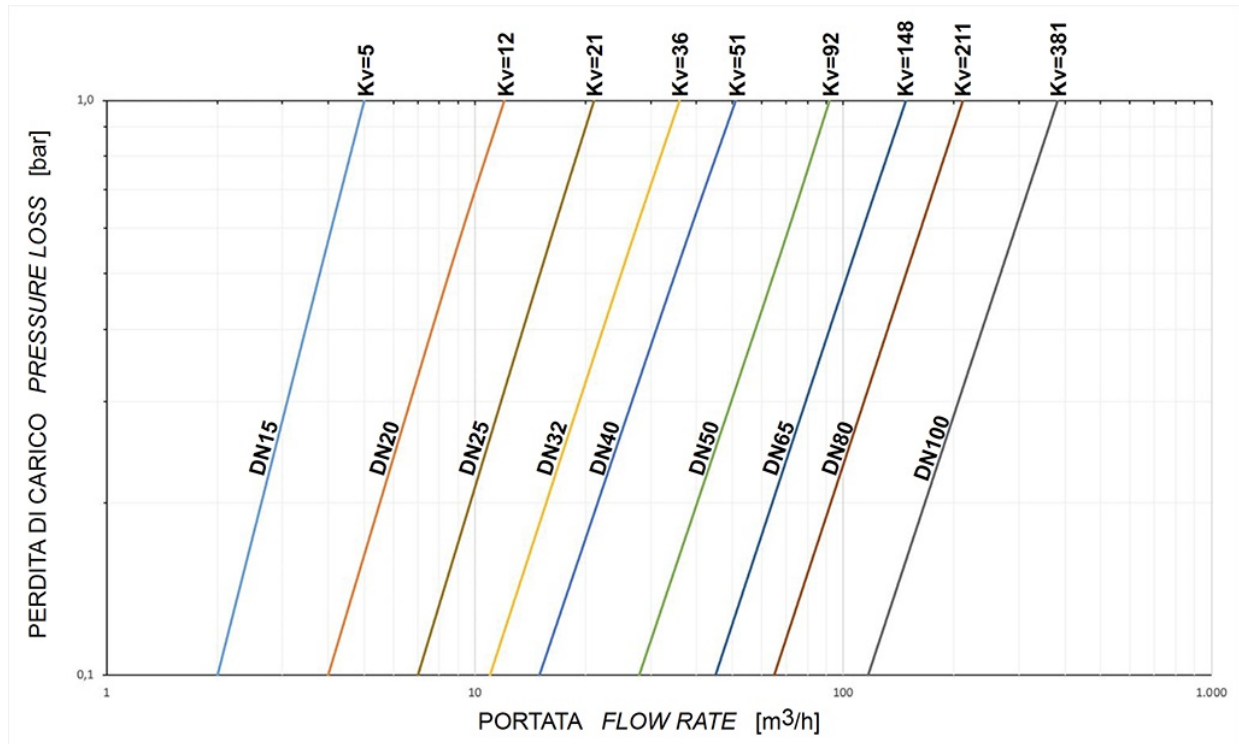

Kv is the coefficient, expressed in m³/h (with water at 15°C) causing a pressure loss of 1 bar.



specifications

Plan for "L" port

N.B.:

"A" must be the rest position of the ball with **SR FAIL CLOSE** actuator.

"B" must be the rest position of the ball with **SR FAIL OPEN** actuator.

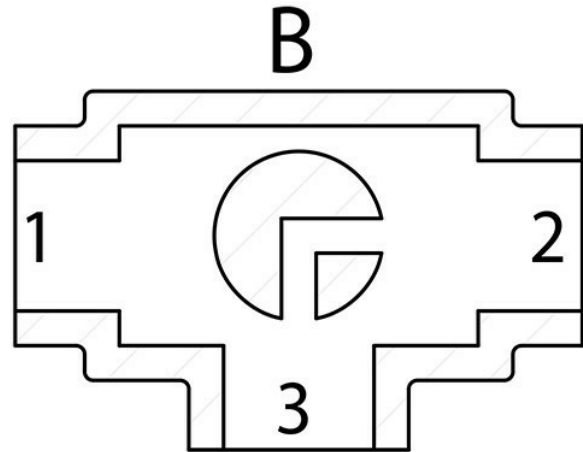
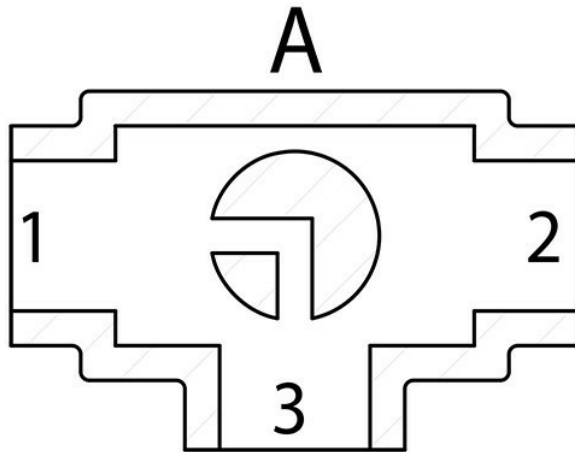

Plan for "T" port

With actuator 2 positions with 90° rotation are possible only: the configuration of the ball must always be communicated at our sales department.

N.B.:

Choose the rest position of the ball with **SR FAIL CLOSE** actuator; whenever supplied with air, actuator turns in an anticlockwise direction.

Choose the rest position of the ball with **SR FAIL OPEN** actuator; whenever supplied with air, actuator turns in a clockwise direction.



A

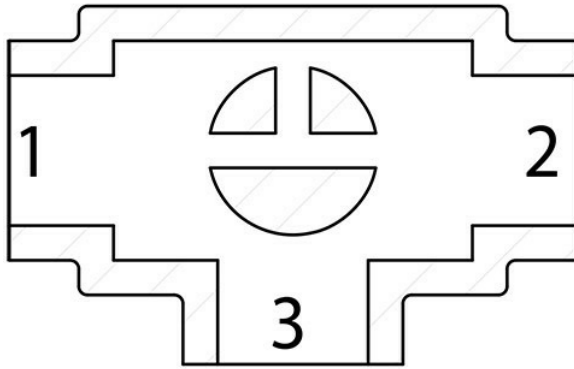

B

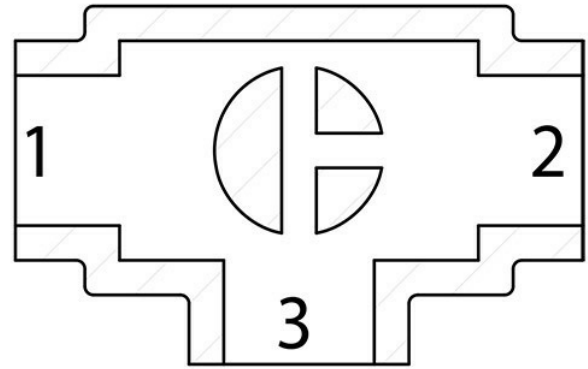

D

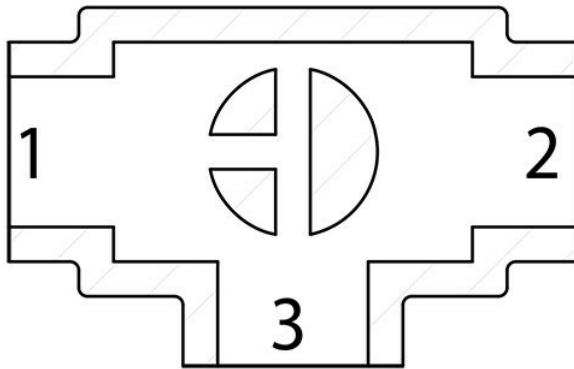

C

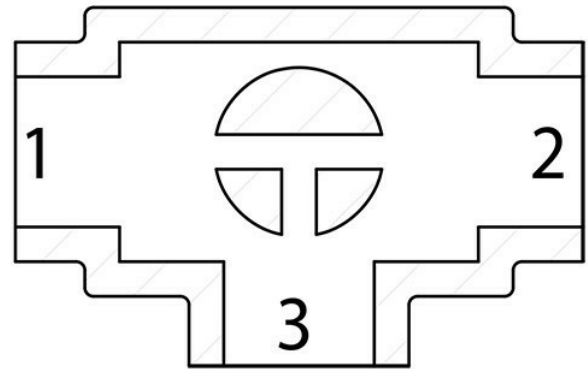



accessories

CASTING STEM EXTENSION WITH LEVER

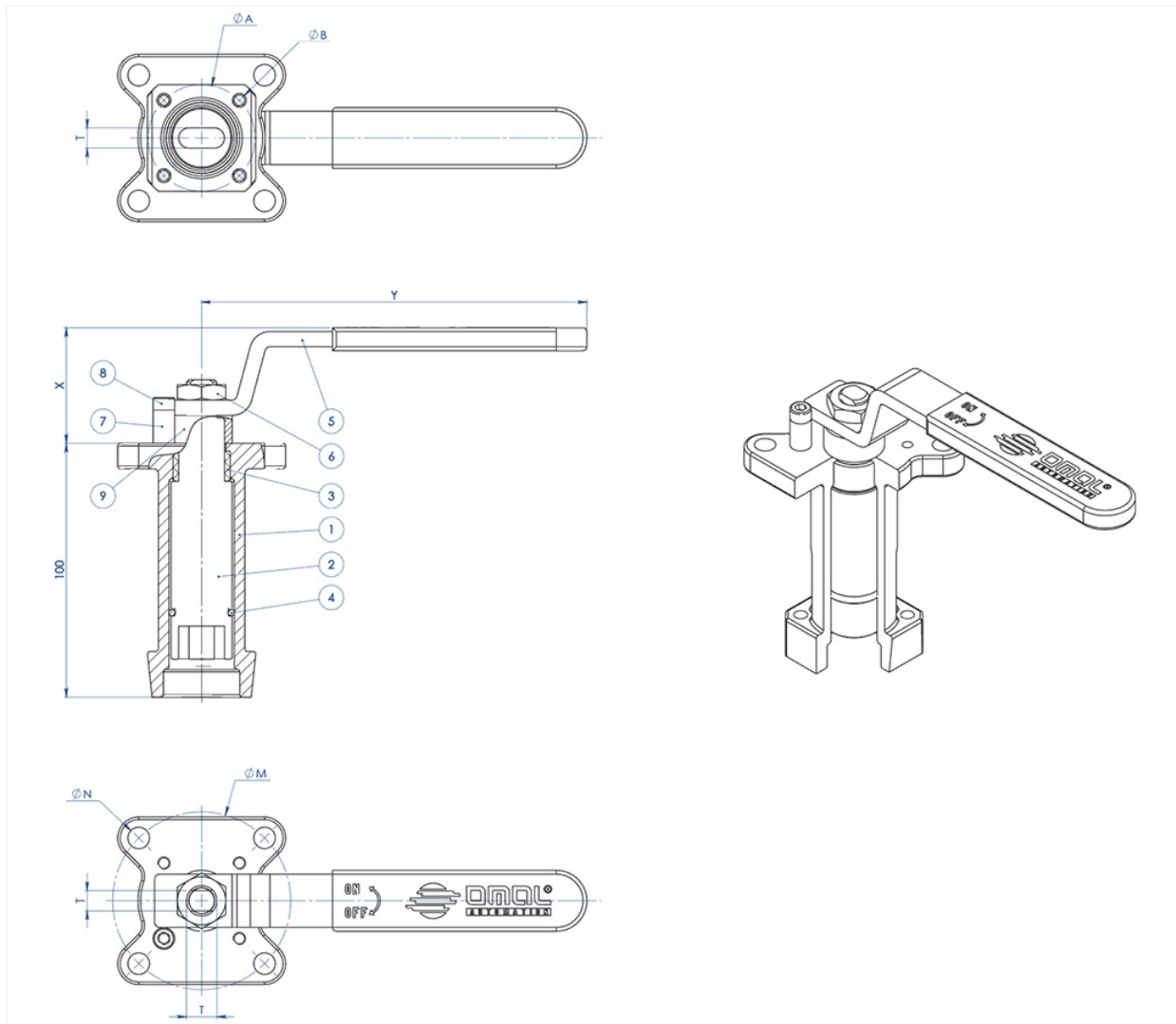

MATERIALS

PART. N°	DESCRIPTION	MATERIAL
1	Extension	AISI304 S.S.
2	Pin	AISI 430 F
3	Bush	DELRIN
4	O-RING	NBR
5	Lever	Fe 37 galvanized (*)
6	Nut	galvanized carbon steel (*)
7	Holder Lever	galvanized carbon steel (*)
8	Holder screw	A2-70
9	Spacer	PTFE Carbon Filled

(*): On request available in Aisi 304 s.s.



DIMENSIONS							
ISO VALVE	ØA	ØB	ØM	ØN	F/T	X	Y
F03	36	5,5	36	5,5	10/6	38,5	141,5
F04	42	5,5	42	M5	12/8	45,5	151,5
F05	50	6,5	50	6,5	16/10	48,5	276,5
F07	70	8,5	70	8,5	22/14	57,5	351,5
F10	102	11	102	11	30/18	79,5	451,5

NOTE: Code of the spindle extension depending from drive's type and valve's connection; to be requested at the order.

CASTING STEM EXTENSION FOR ACTUATORS

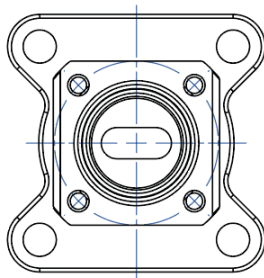

NOTA: Le dimensioni dipendono dalle dimensioni dell'attacco valvola
NOTE: Dimensions depending from valve's connection

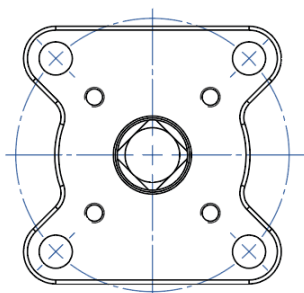
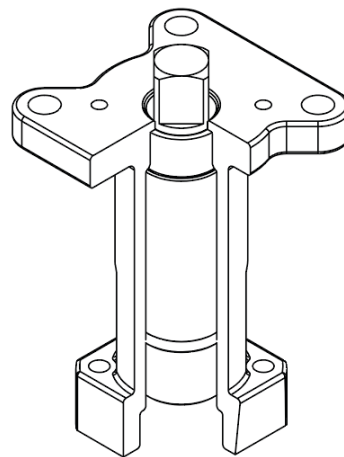
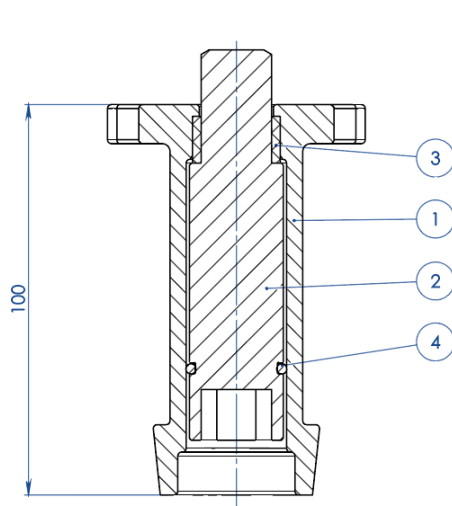

NOTA: Le dimensioni dipendono dalla taglia dell'attuatore
NOTE: Dimensions depending from actuator's size



MATERIALS		
PART. N°	DESCRIPTION	MATERIAL
1	Extension	ASTM A351 CF8M
2	Pin	AISI 430 F
3	Bush	DELTRIN
4	O-RING	NBR

NOTE: Code of the spindle extension depending from drive's type and valve's connection; to be requested at the order

WELDED STEM EXTENSION WITH LEVER

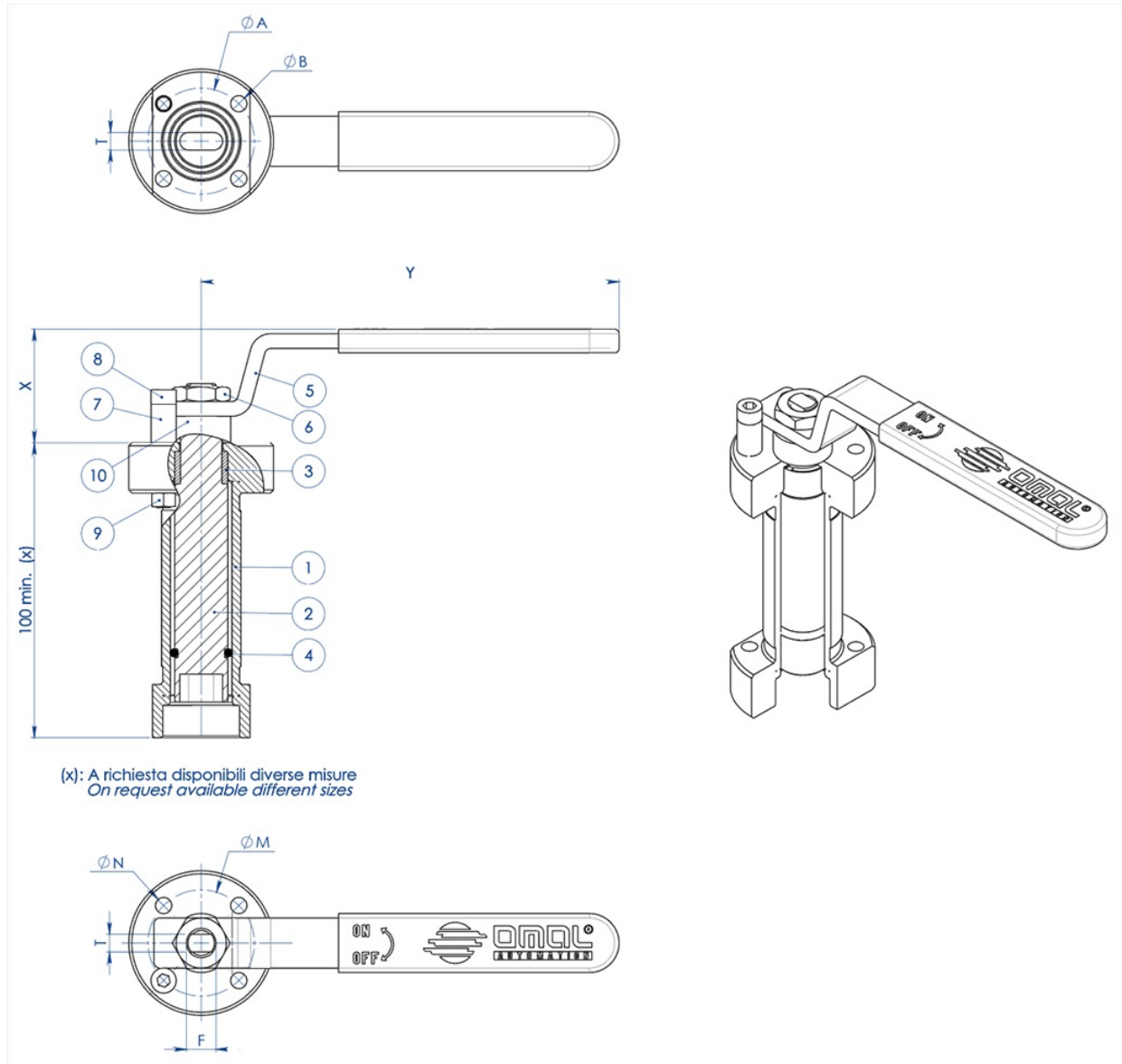



MATERIALS		
PART. N°	DESCRIPTION	MATERIAL
1	Extension	304 s.s.
2	Pin	AISI 430 F
3	Bush	DELTRIN
4	O-Ring	NBR
5	Lever	Fe 37 galvanized (*)
6	Nut	galvanized carbon steel (*)
7	Holder Lever	galvanized carbon steel (*)
8	Holder screw	A2-70
9	Holder nut	A2-70 (**)
10	Spacer	PTFE Carbon Filled

(*): On request available in Aisi 304 s.s.

(**): No available on valves with Iso connection F04

DIMENSIONS							
ISO VALVE	ØA	ØB	ØM	ØN	F/T	X	Y
F03	36	5,5	36	5,5	10/6	38,5	141,5
F04	42	5,5	42	M5	12/8	45,5	151,5
F05	50	6,5	50	6,5	16/10	48,5	276,5
F07	70	9	70	9	22/14	57,5	351,5
F10	102	11	102	11	30/18	79,5	451,5

NOTE: Code of the stem extension depending from drive's type and valve's connection; to be requested at the order.

WELDED STEM EXTENSION FOR ACTUATORS

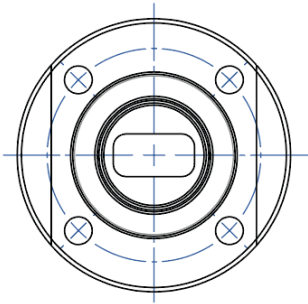

NOTA: Le dimensioni dipendono dalle dimensioni dell'attacco valvola
NOTE: Dimensions depending from valve's connection

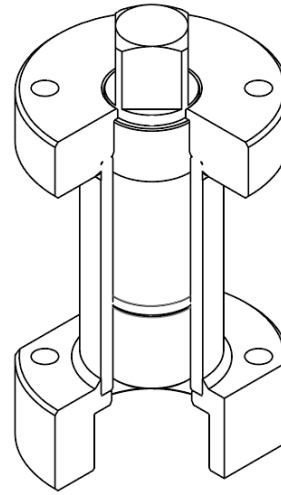
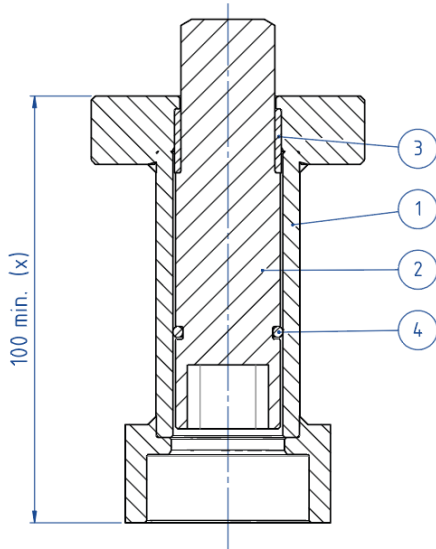

(x): A richiesta disponibili diverse misure
On request available different sizes

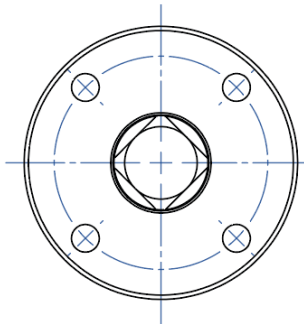

NOTA: Le dimensioni dipendono dalla taglia dell'attuatore
NOTE: Dimensions depending from actuator's size

MATERIALS		
PART. N°	DESCRIPTION	MATERIAL
1	Extension	304 S.S.
2	Pin	AISI 430 F
3	Bush	DELRIN
4	O-RING	NBR

NOTE: Code of the stem extension depending from drive's type and valve's connection; to be requested at the order.



STEM EXTENSION WITH ADDITIONAL SEAL

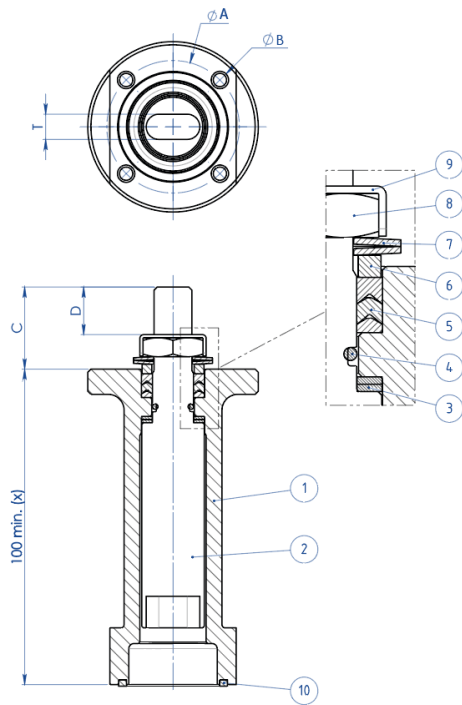

(x): A richiesta disponibili diverse misure
On request available different sizes

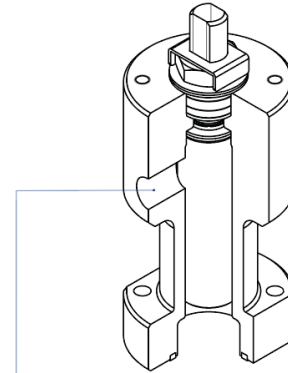
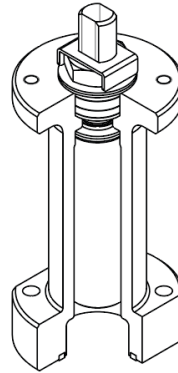

A richiesta disponibile anche la versione con presa per Sniffer
Stem extension with sniffer also available on request

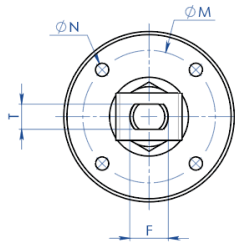

MATERIALS

PART. N°	DESCRIPTION	MATERIAL
1	Extension	304 s.s.
2	Pin	A564 TP.630 (17-4ph)
3	Bottom Sealing	TFM1600
4	O-Ring	FKM
5	Chevron Ring	TFM1600
6	Packing Gland Ring	304 s.s.
7	Spring Washer	50CrV4 Galvanized
8	Stem Nut	UNI 3740-1 6S Galvanized
9	Stop Nut Plate	304 s.s.
10	Gasket	GRAFOIL



DIMENSIONS							
ISO VALVE	ØA	ØB	ØM	ØN	F/T	C	D
F03	36	5,5	36	M5	10/6	20	10,2
F04	42	5,5	42	M5	12/8	26	15,1
F05	50	6,5	50	M6	16/10	35	21,2
F07	70	8,5	70	M8	22/14	47,5	28,4
F10	102	10,5	102	M10	30/18	61	35,2

NOTE: Code of the spindle extension depending from drive's type and valve's connection; to be requested at the order.





documents

Certificati

TA LUFT - MAGNUM & THOR

ATEX - Ball Valves

SIL IEC 61508 - MAGNUM & THOR

FUGITIVE EMISSION DN25 CL.300 T1-T2-T3-M1-M4-M5-M6

FUGITIVE EMISSION DN100 CL.300 T1-T2-T3-M1-M4-M5-M6

PED

UKCA

Manuali

MANUALE UMAH1000

Istruzioni

ISTRUZIONI USO 8_0844-37

